

Samsung Glyde™

**P O R T A B L E A L L D i g i t a l
M O B I L E P H O N E**

User Manual

**Please read this manual before operating your
phone, and keep it for future reference.**



Intellectual Property

All Intellectual Property, as defined below, owned by or which is otherwise the property of Samsung or its respective suppliers relating to the SAMSUNG Phone, including but not limited to, accessories, parts, or software relating there to (the "Phone System"), is proprietary to Samsung and protected under federal laws, state laws, and international treaty provisions. Intellectual Property includes, but is not limited to, inventions (patentable or unpatentable), patents, trade secrets, copyrights, software, computer programs, and related documentation and other works of authorship. You may not infringe or otherwise violate the rights secured by the Intellectual Property. Moreover, you agree that you will not (and will not attempt to) modify, prepare derivative works of, reverse engineer, decompile, disassemble, or otherwise attempt to create source code from the software. No title to or ownership in the Intellectual Property is transferred to you. All applicable rights of the Intellectual Property shall remain with SAMSUNG and its suppliers.

Samsung Telecommunications America (STA), LLC

Headquarters: Customer Care Center:

1301 E. Lookout Drive 1000 Klein Rd.

Richardson, TX 75082 Plano, TX 75074

Toll Free Tel: 1.888.987.HELP (4357)

Internet Address: <http://www.samsungusa.com>

©2008 Samsung Telecommunications America, LLC is a registered trademark of Samsung Electronics America, Inc. and its related entities.

Do you have questions about your Samsung Mobile Phone?

For 24 hour information and assistance, we offer a new FAQ/ARS System (Automated Response System) at:

www.samsungwireless.com/support

GH68-16822A

Printed in Korea

Licensed by Qualcomm Incorporated under one or more of the following patents: U.S.

Patent No. 4, 901, 307; 5, 056, 109; 5, 099, 204; 5, 101, 501; 5, 103, 459; 5, 107, 225; 5, 109, 390.

ACCESS and NetFront are trademarks or registered trademarks of

ACCESS CO., LTD. in Japan and other countries.

Copyright © 1996 - 2006 ACCESS CO., LTD.

RSA® is a registered Trademark RSA Security, Inc.

Disclaimer of Warranties; Exclusion of Liability

EXCEPT AS SET FORTH IN THE EXTouch WARRANTY CONTAINED ON THE WARRANTY PAGE ENCLOSED WITH THE PRODUCT, THE PURCHASER TAKES THE PRODUCT "AS IS", AND SAMSUNG MAKES NO EXTouch OR IMPLIED WARRANTY OF ANY KIND WHATSOEVER WITH RESPECT TO THE PRODUCT, INCLUDING BUT NOT LIMITED TO THE MERCHANTABILITY OF THE PRODUCT OR ITS FITNESS FOR ANY PARTICULAR PURPOSE OR USE; THE DESIGN, CONDITION OR QUALITY OF THE PRODUCT; THE PERFORMANCE OF THE PRODUCT; THE WORKMANSHIP OF THE PRODUCT OR THE COMPONENTS CONTAINED THEREIN; OR COMPLIANCE OF THE PRODUCT WITH THE REQUIREMENTS OF ANY LAW, RULE, SPECIFICATION OR CONTRACT PERTAINING THERETO. NOTHING CONTAINED IN THE INSTRUCTION MANUAL SHALL BE CONSTRUED TO CREATE AN EXTouch OR IMPLIED WARRANTY OF ANY KIND WHATSOEVER WITH RESPECT TO THE PRODUCT. IN ADDITION, SAMSUNG SHALL NOT BE LIABLE FOR ANY DAMAGES OF ANY KIND RESULTING FROM THE PURCHASE OR USE OF THE PRODUCT OR ARISING FROM THE BREACH OF THE EXTouch WARRANTY, INCLUDING INCIDENTAL, SPECIAL OR CONSEQUENTIAL DAMAGES, OR LOSS OF ANTICIPATED PROFITS OR BENEFITS.

Table of Contents

Section 1: Getting Started 4

Understanding this User Manual	4
Notes and Tips	4
Using the Battery	4
Turning Your Phone On and Off	9
Locking and Unlocking the Display	10
Setting Up Voicemail	10

Section 2: Understanding Your Phone 11

Features of Your Phone	11
Closed View of Your Phone	12
Open View of Your Phone	13
Event Status Bar and Event Manager	17
Menu Screen Layout	19
Command Bar Buttons	19
Care and Use of the Touch Screen	20
Dialog Boxes	20

Section 3: Touch Screen Navigation 21

Touch Screen Navigation	21
Keyboard Navigation	22
My Shortcuts	22
Menu Outline	23

Section 4: Call Functions 27

Making a Call	27
Ending a Call	27

Three-way Calling	27
Answering a Call	28
Call In-Progress Options	29
Recent Calls	29
Roaming	33
TTY	33
Voice Commands	34

Section 5: Understanding Your Contacts 39

Contacts Icons	39
Adding a Contact	39
Adding Pauses	42
Contact Groups	42
Finding a Contact Entry	46
Editing an Existing Contact Entry	46
Deleting a Contact Entry	46
Speed Dialing	47
My Name Card	48
Finding My Phone Number	49
Emergency Contacts	49

Section 6: Selecting Text Entry Modes 51

Changing Text Entry Mode with the Touch Keypad	51
Changing Text Entry Mode with the Slide-out Keyboard	51
Creating a Text Message with the Touch Keypad	51
Creating a Text Message with the Slide-out QWERTY Keyboard	53

Section 7: Messaging	56
Types of Messages	56
Retrieving New Messages	56
Creating and Sending Text Messages	57
Creating and Sending Picture Messages	58
Creating and Sending Video Messages	60
Receiving Picture Messages	61
Receiving Video Messages	62
Message Folders	63
Changing Message Settings	69
Voicemail	70
Mobile IM	70
Section 8: Changing Your Settings	72
My Account	72
Tools	72
Bluetooth Menu	72
Sound Settings	75
Touch Settings	77
Display Settings	77
Phone Settings	80
Call Settings	85
Memory	88
Phone Info	89
Section 9: Get It Now	90
Get It Now	90
Music & Tones	90

Picture & Video	95
Games	105
Internet Browser	105
Browse & Download	106
Extras	106
Section 10: Tools	107
Voice Commands	107
Calculator	107
Calendar	109
Alarm Clock	110
Stop Watch	112
World Clock	112
Notepad	112
Section 11: Browser	114
Browser	114
Launching Browser	114
Navigate the Web	115
Links	115
Place a call while using the Browser	116
Exit Browser	116
Section 12: Health and Safety Information	117
Health and Safety Information	117
Samsung Mobile Products and Recycling	118
UL Certified Travel Adapter	118
Consumer Information on Wireless Phones	119
Road Safety	124

Responsible Listening	126
Operating Environment	127
Using Your Phone Near Other Electronic Devices	128
FCC Hearing-Aid Compatibility (HAC) Regulations for Wireless Devices	128
Potentially Explosive Environments	130
Emergency Calls	130
FCC Notice and Cautions	131
Other Important Safety Information	132
Product Performance	132
Availability of Various Features/Ring Tones	133
Battery Standby and Talk Time	133
Battery Precautions	133
Care and Maintenance	135
Section 13: Warranty Information	136
Standard Limited Warranty	136
Index	140

Section 1: Getting Started

Understanding this User Manual

The chapters of this manual generally follow the same order as the menus and sub-menus in your Samsung Glyde™. A robust index for quick reference to most features begins on page 140.

Also included is important safety information that you should know before using your Glyde™. Most of this information is near the back of the guide, beginning on page 117.

Notes and Tips

Throughout this guide are icons and text that are set apart from the rest. These are intended to point out important information, quick methods for activating features, to define terms, and more. The definitions for these methods are as follows:

- **Notes:** Explain alternative options within the current feature, menu, or sub-menu.
- **Tips:** Provide quick or innovative methods for performing functions related to the subject at hand.
- **Important:** Points out important information about the current feature that could affect performance, or even damage your phone.

This section allows you to start using your Glyde™ after activating your service, setting up your voicemail, contacting customer support, or getting an understanding of how this manual is put together.



Using the Battery

Note: This phone comes packaged with a partially charged rechargeable standard Li-Ion battery and travel charger.

You must fully charge the battery before using your phone for the first time. A fully discharged battery requires up to 4 hours of charge time.

Important! Although the phone can be used while the battery is charging, the battery must be fully charged before first use, otherwise you could damage the battery.

Battery Indicator

The battery indicator  in the upper-right corner of the display indicates battery power level. Four bars indicate a full charge, while an empty icon  indicates an almost empty battery. Two to three minutes before the battery becomes too low to operate, a blinking empty battery icon  appears and a tone sounds. If you continue to operate the phone without charging, it shuts down.

Using A Non-Supported Battery

Samsung handsets do not accept the use of a non-supported battery.

When using a non-supported battery, you will hear a series of beeps and you will see a warning message that indicates:

“NON SUPPORTED BATTERY. SEE USER GUIDE”

If you receive this warning, battery charging has been disabled.

Samsung charging accessories (i.e. travel adapter, and cigarette lighter adapter) will only charge a Samsung-approved battery.

Note: When using a non-supported battery the handset can only be used for the duration of the life of the battery and cannot be recharged.

Important! Using a non-supported battery may cause damage to your Glyde™. Use a Samsung supported battery only.

Installing the Battery

1. Push the top of the battery cover forward. Lift the bottom of the battery cover to remove it.

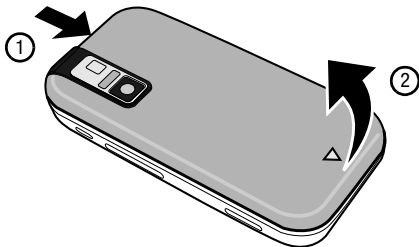

2. Insert the top end of the battery into the phone housing using the directional arrow printed on the battery. The gold contacts at the battery end must align with contacts on the phone. Push bottom end of the battery down until it snaps into place.

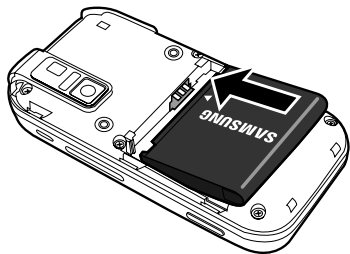

3. Insert the top of the battery cover down into the corresponding slots (positioned on each side of the headset cover). Push down on the bottom of the battery cover and push it up until it snaps into place.

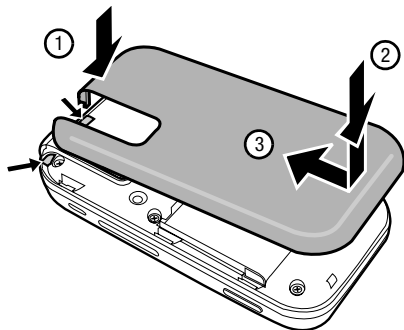

Removing the Battery

1. Push the top of the battery cover forward. Lift the bottom of the battery cover to remove it.

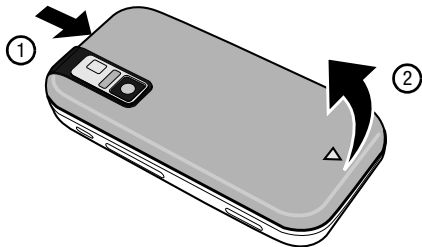

2. Lift the battery from the bottom end and remove.

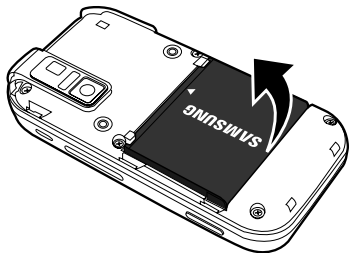

3. Insert the top of the battery cover down into the corresponding slots (positioned on each side of the headset cover). Push down on the bottom of the battery cover and push it up until it snaps into place.

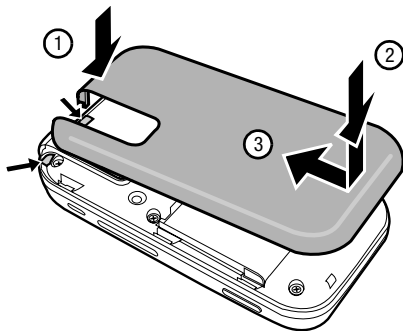

Installing the Memory Card

1. Push the top of the battery cover forward. Lift the bottom of the battery cover to remove it.

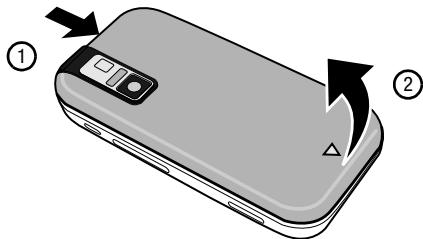

2. Insert the memory card in the memory card slot fully until it clicks into place.

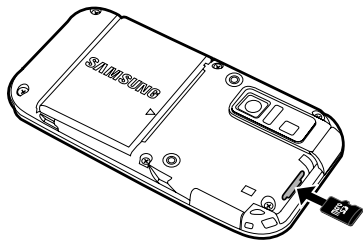

Removing the Memory Card

1. Push the top of the battery cover forward. Lift the bottom of the battery cover to remove it.

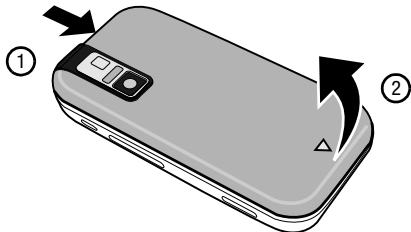

2. Push in on the memory card to release the lock and remove memory card from the memory card slot.

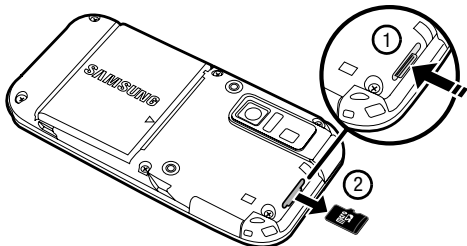

Charging the Battery

Your Glyde™ is powered by a rechargeable standard Li-ion battery. Only use Samsung-approved charging devices and batteries. Samsung accessories are designed to maximize battery life. Using other accessories may invalidate your warranty and may cause damage.

Travel Charger

The travel charger is a convenient, light-weight charger that rapidly charges your Glyde™ from any 120/ 220 VAC outlet.

1. Turn the connector cover to access the charger port. Insert the travel charger adapter end into the charging port on the left side of the Glyde™.

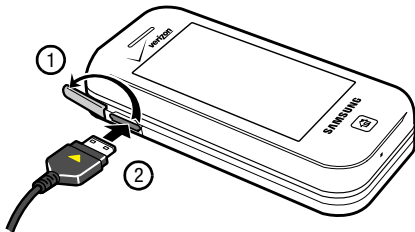

2. Plug the travel charger into a standard AC wall outlet.

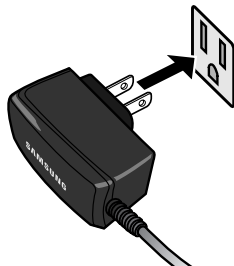

When the Glyde™ is completely charged (the battery icon becomes still), unplug the adapter from the power outlet.

Turning Your Phone On and Off

- Press and hold the **Power/Lock/Unlock**  key to turn the phone's power on or off.



Locking and Unlocking the Display

Press the **Power/Lock/Unlock** key  briefly on the side of the phone to lock the display while the backlight is on. The backlight will turn off after 15 seconds (default) of non-use and automatically lock the display. The time-out period may be adjusted, see “*Backlight*” on page 78.

If the display is locked, and the display has timed out, touch any exterior key to illuminate the display. If the display is locked, a prompt “ **TOUCH TO UNLOCK**” next to a **Padlock icon**  displays. Touch the **Padlock icon**  to unlock the display.







Because this is a touch screen phone, keeping the phone in Lock mode may prevent the unintentional use of the Glyde™, and prevent unnecessary battery drainage. However, Auto Lock can be disabled under Touch Settings.

Setting Up Voicemail







Voicemail allows callers to leave voice messages, which can be retrieved any time.

Note: Once your voicemail account has been set up, you can use the voicemail selection 5 (under the Messaging menu) to view details of voice messages in your voicemail box.

Voicemail Setup*

1. From the Home screen, touch  **Dial Pad**.
2. Touch and hold  or touch     from the touch keypad or QWERTY keyboard, or dial your wireless phone number from any touch-tone phone.
3. When the recorded announcement begins, touch  to interrupt (if applicable).
4. An easy-to-follow setup tutorial will begin. Follow the instructions to set up your new password and record a greeting.

Listening to Voicemail

1. Touch and hold  or touch    .
2. Touch the **Padlock icon**  to unlock the display. Enter your password followed by  key.
3. Follow the recorded prompts to listen to messages, change administrative options, and so on.

*Airtime and long distance charges apply. IN Calling minutes do not apply to Voicemail setup or retrievals.

Section 2: Understanding Your Phone

This section outlines key features of your phone. It also displays the screen and the icons that are displayed when the phone is in use.

Features of Your Phone

- Full Color Touch Screen with a slide-out QWERTY keyboard
- High Speed Data (EVDO 1x Technology)
- Global Positioning (GPS) Technology for VZ NavigatorSM
- V CAST Music and Video Capable
- Personal Organizer (Calculator, Calendar, Alarm Clock, Stop Watch, World Clock, and Notepad)
- HTML Browser
- Messaging Services (Standard and Enhanced TXT Messaging, Picture Messaging, Video Messaging, Sketch Messaging, Postcard, Mobile Email, and Mobile Instant Messenger)
- 2 Megapixel Camera and Camcorder with Flash
- Advanced Speech Recognition
- Stereo Speaker and 2-way Speakerphone
- microSDTM Memory Card Slot
- Bluetooth[®] Wireless Technology ^{**}

Note: ^{**}The Samsung GlydeTM supports the following Bluetooth profiles: Headset, Hands-free, Serial Port, Dial Up Networking, Object Push for vCard, Phonebook Access, Bluetooth Stereo Support for Music, Basic Imaging Push for sending/printing non-protected images to a compatible device, and Basic Printing Profile. The GlydeTM does not support all Bluetooth OBEX profiles. Go to www.verizonwireless.com/bluetoothchart.

Closed View of Your Phone

The following illustration shows the main external features of your phone.



Phone External Features

1. **Speaker:** Music, Ringtones, and Sounds are played through the speaker. These speakers provide stereo sound for multimedia files.
2. **Earpiece:** Allows you to hear the other caller.
3. **Power/Accessory Port:** Used to plug in the charging accessories and also connect any available accessory cables to your phone.
4. **Main LCD/Touch Screen:** Displays all the information needed to operate your phone.
5. **Home Key:** Allows you return to the Home screen from anywhere in the Menu functions, or cancels functions. You may also press the Home key to turn on the backlight and unlock the display during a call, and to end a call.
6. **Microphone:** Allows the other caller to hear you clearly when you are speaking to them.
7. **Power/Lock/Unlock Key:** Powers the phone On or Off with a long press. Locks/unlocks display with a short press when power is On. Activates the backlight.

8. **Volume key:** Adjusts the master volume or adjusts the voice volume during a call. To mute the ringer during an incoming call, press the volume key up or down. Also, press and hold the key to activate Sound Off mode/Normal mode.
9. **Camera/Camcorder key:** Press to activate the camera, or press and hold to activate the camcorder.
10. **Mirror:** Allows for self-portraits.
11. **Camera/Camcorder lens:** The lens of your built-in camera/camcorder.
12. **Headset Jack:** Allows you to plug in an optional headset for safe, convenient conversations.
13. **Flash:** The built-in flash has manual and automatic capabilities.
14. **microSD™ Memory Card Slot:** (located under back cover). Allows you to insert a microSD™ memory card to add additional memory and storage capacity.

Open View of Your Phone

This touch screen phone also offers the convenience of a slide-out QWERTY keyboard. To open the phone to access the keyboard, rotate the phone 90 degrees to the left. Slide the top section of the phone up to open, as shown in the illustration below.



When you slide the phone open, the display rotates from a vertical viewing mode to a horizontal viewing mode.



QWERTY Keyboard Features



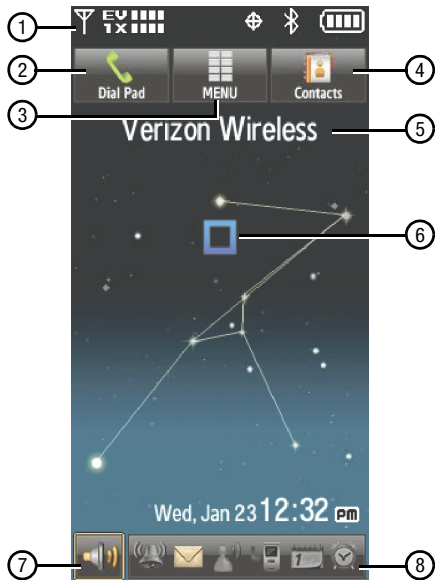

1. **QWERTY Keyboard:** Provides an alphanumeric character keyboard layout.
2. **Shift Key:** Toggles the casing for alphabet characters between mixed case, uppercase and lowercase. Case will remain as selected until the Shift key is pressed again.

3. **Fn Key:** The **Fn (Function)** key, toggles to access the yellow numbers/symbols on the QWERTY keyboard. The **Fn** icon will appear on the top annunciator line of the display when function is On.
4. **Space Key:** Allows you to add spaces between words and characters.
5. **Enter Key:** Press to perform the function highlighted in the menu or submenu. Press to enter spaces between lines of text.
6. **Back/Clear Key:** Deletes characters from the display when you are in text entry mode. Press to return to the previous menu or screen when navigating features.

Home Screen Layout





Understanding the Home Screen

1. The **Annunciator Line**, which is the top line of your phone's display, shows icons that indicate network status, battery power, signal strength, connection type and more.
2. The **Dial Pad** button  allows you to access the touch keypad for dialing numbers.
3. The **Menu** button  allows you to access the **Main Menu** screen.
4. The **Contacts** button  allows you to access your Contact list.
5. The ERI banner indicates the service provider.
6. The **My Shortcuts** icon  allows you to access the **MY SHORTCUTS** menu.
7. The **Speakerphone** button  shows you the current status of the speakerphone, and allows you to set the speakerphone to On or Off.
8. The **Event Status** touch bar of the home screen illuminates the icons to indicate recent events or status changes. Touch this bar to access the **Event Manager** screen. See "Event Status Bar and Event Manager" on page 17.

Annunciator icons

 **Standalone Mode:** Appears when Standalone Mode is on. When on, all RF functions for your phone are disabled, and you cannot use your phone to place or receive calls.

 **Roaming:** Your phone is outside your home area. While roaming, another wireless provider may be handling your call. The service rate for the call may be higher than those made from within your home area. Please refer to Verizon Wireless for roaming rates.

 **EV signal strength:** Appears when your phone is using the EVDO protocol. Appears when your phone is on and indicates the current signal strength. More bars indicate a stronger signal.

 **1X signal strength:** Indicates your phone is using the CDMA 1X protocol. Appears when your phone is on and indicates the current signal strength. More bars indicate a stronger signal.

 **EV1X signal strength:** The EVDO/1X protocol is capable of high-speed broadband data (3G). Appears when your phone is on and indicates the current signal strength. More bars indicate a stronger signal.

 **D signal strength:** Appears when your phone is receiving digital data. Appears when your phone is on and indicates the current signal strength. More bars indicate a stronger signal.

 **SSL:** Indicates the secure socket layer is actively transmitting your communications over the internet in an encrypted format.









 **Voice Privacy:** Prevents eavesdropping over a CDMA traffic channel.

 **Hold-Keys Lock:** Indicates that the display is locked and not functional. Touch the large onscreen padlock when prompted to unlock the display.

 **No service:** Your phone cannot find a signal because you're outside a service area. You cannot make or receive calls. Wait for a signal or move to an open area to find a signal. This indicator always appears when you first turn on your phone and disappears once service is located.

 **Voice Call:** Indicates a call in progress.

 **Data Call:** Indicates a data call in progress.

-  **Dormant:** Indicates no incoming or outgoing data.
-  **E911:** Indicates Global Positioning Service (GPS) for 911 is set to On for emergency calls only.
-  **Location On:** Global Positioning Service is set to On for location and 911 calls.
-  **Battery Level:** More bars indicate a greater charge. When the battery is low, an empty battery icon flashes and the phone sounds an alert, which indicates your phone is about to shut down.
-  **TTY:** Indicates that TTY is enabled.
-  **Bluetooth On:** Indicates that Bluetooth wireless technology is turned on.
-  **Bluetooth Connected:** Indicates Bluetooth wireless technology is turned on and is paired with another Bluetooth-enabled device.
-  **Bluetooth Active:** Indicates that Bluetooth wireless technology is connected to another device and receiving or pushing data.

Event Status Bar and Event Manager

The Event Status bar appears on the bottom of the Home screen display.



If an icon is illuminated in color on the front display, it indicates a recent event for that function. Touching on the bar activates the Event Manager menu.

The following list contains icons that appear in the Event Status bar.



Speakerphone On: Your phone will be heard through the speaker.



Speakerphone Off: Your phone audio will be heard through the earpiece.



Volume: The level of the ringer is set between Low and High in five incremental stages: Low, Medium Low, Medium, Medium High, and High.



Alarm Only: Your phone will only ring when the set alarm sounds.



Vibrate Only: Your phone vibrates upon receiving a call.



All Sounds Off: All sounds have been disabled for your phone.



New Messages: This icon is illuminated when you've received a new text, page or web alert message. You're also notified of a new message by animations and sound.



Voicemail: This icon illuminated when you've received a voicemail message, page or web alert message. You have one or more unread voicemail messages in your voicemail box. (Only applicable on the Verizon Wireless Network.)



Missed Calls: This icon illuminated when you have missed calls.



Calendar Appt: This icon illuminated when you have any events scheduled within the next 24 hours.



Alarm On: This icon illuminated when you have any alarms scheduled within the next 24 hours.

Event Manager Menu

The Event Manager menu offers easy access to common functions. Touch the icons or text in the Event Manager menu to perform the action shown in the illustration below.

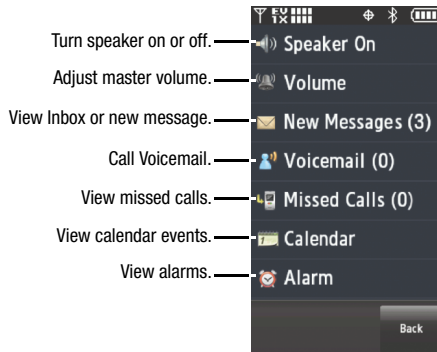

Note: Icons on the Event Status bar and Event Manager screen will be in color to indicate new and upcoming events.

Menu Screen Layout

The Samsung Glyde™ uses a touch screen that displays menus, sub-menus and other icons for operation of the phone.

When you access menus and applications on the phone, the top icons (signal strength, battery level, etc.) of the display remain the same as the Home screen, but the command bar buttons at the bottom may change function depending upon your place in the menu.

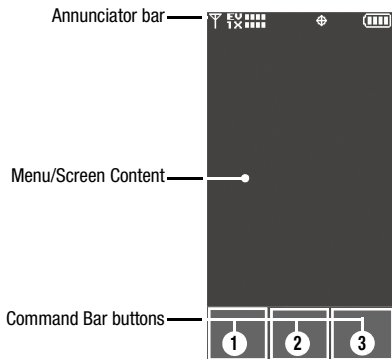

Refer to the following general layout and functions of the command bar buttons shown in the illustration at left:

- 1. Primary button:** Touch to perform the primary function on the screen (indicated in ALL CAPS on the button).
- 2. Options button:** Touch to access other functions that can be done in addition to the primary button function.
- 3. Back/Clear button:** Touch to return to a previous menu, or to clear text in a text field.

Command Bar Buttons

Back Button

The **Back** button is used within the menu structure to return to a previous menu. Touch once for each menu level.

- To back up one menu level, briefly touch **Back**.

Clear Button

The **Clear** button erases or clears numbers, text, or symbols from the within the text fields. If you enter an incorrect character, touch **Clear** to backspace (and delete) the character. To erase the previous word in a sentence, touch and hold **Clear**.

Options Button

The **Options** button offers other functions that can be done in addition to the primary button function.

End Button

The **END** button is used to end a call.

Note: You may also press the  Home key to end a call.

Answer Button

The **ANSWER** button is used to activate or answer calls.

Call Button

Enter a number and touch **CALL** to make a call. Touch **ANSWER** to pick up a waiting call while already on a call.

Touch **SWITCH** to switch back and forth between two active calls.

Care and Use of the Touch Screen

The precautions below should be followed when using the touch screen.

- Hands and fingers must be clean and dry. The touch screen is sensitive. Do not use excess force when using the touch screen. Sensitivity levels for the touch screen are adjustable. For more information, refer to “*Touch Settings*” on page 77.
- The finger tips (not fingernails) should be used when touching the screen. Do not use a stylus or any pointed object for the touch screen. Touching an icon off-center may activate an icon or function.

- Keep all metals and conductive materials away from the touch screen. Contact with metals and conductive materials may cause electrical interference.
- Do not sit or place heavy objects on the touch screen as damage may occur. Do not drag or scratch the touch screen with any sharp objects.
- Avoid extreme conditions (excess temperatures and humidity) when the phone is in use. Keep chemicals away from your phone that may damage or change the phone’s appearance and functionality.
- Use a soft, clean, dry cloth to wipe the display and remove fingerprints.

Dialog Boxes

Dialog boxes prompt for action, inform you of status, or warn of situations such as low memory. Dialog boxes and their definitions are outlined below.

- **Choice** -Example: “SAVE MESSAGE?”
- **Confirm** -Example: “ERASE ALL MESSAGES?”
- **Performing** -Example: “SENDING...” “CONNECTING...”
- **Completed** -Example: “MESSAGE SENT”
- **Information** -Example: “NEW MESSAGE”
- **Error** -Example: “SYSTEM ERROR!”
- **Warning** -Example: “BATTERY LOW,” “MEMORY FULL!”

Section 3: Touch Screen Navigation

This section explains the navigation between functions for your Samsung Glyde™. It also includes an outline of all the available menus associated with your phone.



NOTE: Throughout the Glyde™ User Manual, instructions apply to **Touch Screen Navigation**, except where noted. For information on using the Touch Screen, see “*Menu Screen Layout*” on page 19.

Touch Screen Navigation

Access menus using the touch screen.

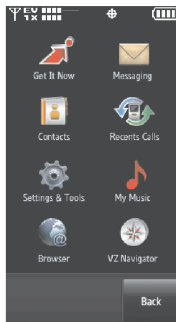
1. From the home screen, touch  **MENU**. The first of several menus appear in the display, as shown in the illustration at right.
2. Touch the various icons to browse phone menus or to start a corresponding application.
3. In menus other than the Main Menu and My Shortcuts, touch the menu item text to access that feature.



4. Touch  **Back** to return to the previous menu. Press the  **Home** key to return to the Home screen.

Touch Screen Scrolling



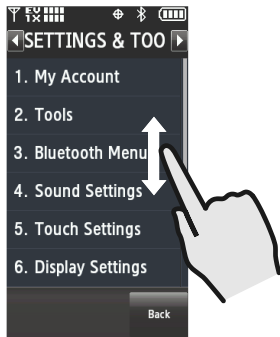



When a menu has more items than can appear on the display, a light gray scroll bar appears on the right of the screen. You may touch and drag text on the screen up or down in the direction you want to move it, or use your finger to quickly flick the text in the direction you want it to move.



Keyboard Navigation



Access menus using the slide-out QWERTY keyboard.

1. From the home screen, touch  **MENU**. The first of several menus appear in the display.
2. Touch the various icons to browse phone menus.
3. Touch the menu item text to enter the menu or sub-menu appearing in the display or press the corresponding number keys  —  to access the sub-menu. You can press the arrow keys  or  to scroll up or down in a menu or long text screen.
4. Press the  **Back/Clear** key to return to the previous sub-menu or menu.



My Shortcuts

My Shortcuts is a method to put the most frequently used functions within two touch strokes. The contents of My Shortcuts menu are editable.



Accessing My Shortcuts

1. On the Home screen, touch  **My Shortcuts** until My Shortcuts menu displays. Touch the desired icon to open.

Modifying My Shortcuts

1. On the Home screen, touch  **My Shortcuts** until My Shortcuts menu displays.
2. Touch . The **'TAP TO REPLACE'** header displays.
3. Touch the icon you would like to replace. The **'REPLACE SHORTCUT'** displays with a list of replacement shortcuts.
4. Touch the desired replacement shortcut, or touch **None** (at end of list) to remove the shortcut from My Shortcuts.

If you selected **None** to remove the shortcut and would like to reassign a shortcut to the empty slot, use the following steps:

1. On the Home screen, touch  **My Shortcuts** until My Shortcuts menu displays. Touch .

2. Touch the area marked **'Touch to Assign'**. Touch a desired shortcut to populate the unassigned slot.

Note: While in the **TAP TO REPLACE** menu, touch  **Reset** to reset all shortcuts to the default settings.

Menu Outline

The following list shows the menu structure and indicates the number assigned to each option.

Get It Now

- 1: Music & Tones
 - 1: V CAST Music
 - 2: Shop Ringtones
 - 1: Shop Ringtones
 - 3: My Ringtones
 - 1: Shop Ringtones
 - 1: Shop Ringtones
 - 4: My Music
 - 5: My Sounds
 - 1: Record New
 - 6: Sync Music
- 2: Picture & Video
 - 1: V CAST Videos
 - 2: Get New Pictures

- 1: Shop Pictures
- 3: My Pictures
- 4: My Videos
- 5: Take Picture
- 6: Record Video
- 7: Online Album

- 3: Games
 - 1: Shop Games
- 4: Internet Browser
- 5: Browse & Download
 - 1: Browse & Shop
- 6: Extras
 - 1: Shop Extras

Messaging

- 1: New Message
 - 1: TXT Message
 - 2: Picture Message
 - 3: Video Message
 - 4: Sketch Message
 - 5: Postcard
- 2: Inbox
- 3: Sent
- 4: Drafts
- 5: Voicemail

6: Mobile IM

Contacts

- 1: New Contact
- 2: Contact List
- 3: Groups
 - 1: No Group
 - 2: Business
 - 3: Colleague
 - 4: Family
 - 5: Friends
- 4: Speed Dials
- 5: Emergency Contacts
- 6: My Name Card

Recent Calls

- 1: Missed
- 2: Received
- 3: Dialed
- 4: All
- 5: View Timers

Settings & Tools

- 1: My Account

2: Tools

- 1: Voice Commands
- 2: Calculator
 - 1: Normal
 - 2: Tip
 - 3: Converter
- 3: Calendar
- 4: Alarm Clock
- 5: Stop Watch
- 6: World Clock
- 7: Notepad
- 3: Bluetooth Menu
 - 1: Add New Device
- 4: Sound Settings
 - 1: Call Sounds
 - 1: Call Ringtone
 - 1: Shop Ringtones
 - 2: Call Vibrate
 - 2: Alert Sounds
 - 1: TXT Message
 - 1: Tone
 - 1: Shop Ringtones
 - 2: Vibrate
 - 3: Reminder
 - 2: Picture-Video Msg

- 1: Tone
 - 1: Shop Ringtones
- 2: Vibrate
- 3: Reminder
- 3: Voicemail
 - 1: Tone
 - 1: Shop Ringtones
 - 2: Vibrate
 - 3: Reminder
- 4: Device Connect
- 5: Emergency Tone
- 3: Keypad Sounds
- 4: Keypad Volume
- 5: Service Alerts
 - 1: ERI
 - 2: Minute Beep
 - 3: Call Connect
 - 4: Service Change
- 6: Power On/Off
 - 1: Power On
 - 2: Power Off
- 5: Touch Settings
 - 1: Auto Lock
 - 2: Vibrate Level
 - 3: Sensitivity Level

- 6: Display Settings
 - 1: Banner
 - 1: Personal Banner
 - 2: ERI Banner
 - 2: Backlight
 - 1: Display
 - 1: Duration
 - 2: Brightness
 - 2: Keypad
 - 3: Wallpaper
 - 1: My Pictures
 - 2: My Videos
 - 4: Dial Font Size
 - 5: Clock Format
- 7: Phone Settings
 - 1: Standalone Mode
 - 2: Set My Shortcuts
 - 3: Voice Commands
 - 1: Digit Dial Readout
 - 2: TXT Msg Readout
 - 3: Choice List
 - 4: Sensitivity
 - 5: Train Voice
 - 6: Prompts
 - 7: Call Alert

- 4: Language
- 5: Location
- 6: Security
- 7: System Select
- 8: NAM Select

8: Call Settings

- 1: Answer Options
- 2: Auto Retry
- 3: TTY Mode
- 4: One Touch Dial
- 5: Call Screen Layout
- 6: Voice Privacy
- 7: Data Settings
- 8: DTMF Tones

9: Memory

- 1: Save Options
 - 1: Pictures
 - 2: Videos
 - 3: Sounds
- 2: Phone Memory
 - 1: Phone Memory Usage
 - 2: My Pictures
 - 3: My Videos
 - 4: My Ringtones

5: My Music

6: My Sounds

3: Card Memory

1: Card Memory Usage

2: My Pictures

3: My Videos

4: My Music

5: My Sounds

0: Phone Info

1: My Number



2: SW/HW Version

3: Icon Glossary

Section 4: Call Functions

This section describes how to make, answer or end a call. It also includes the features and functionality associated with making, answering or ending a call.



Making a Call





1. From the Home screen, touch  **Dial Pad**. The touch keypad displays.
2. Touch the numbers to call using the touch keypad and touch . Remember to include necessary long distance codes. Touch and hold to dial a speed dial number.
-or-
 1. Open slide of phone.
 2. Enter digits, or press  **Function** to change to alphabetic mode. Phone numbers may be entered in either numeric or alphabetic mode using the QWERTY keyboard, but will be converted to numeric when dialed and saved.



Note: If the number(s) entered is a speed dial location, the phone number associated with that location will be dialed.

Ending a Call

Follow the steps below to end a call.

1. If the backlight is off, press the  **Home** key or the  **Power/Unlock** key to turn on the backlight and to unlock the display.

Note: If the backlight is on but the display is locked, you may press the  **Home** key or the  **Power/Unlock** key to unlock the display, or touch the  **Padlock** icon on the prompt " **TOUCH TO UNLOCK**".

2. Press the  **Home** key or touch the  button to disconnect the call.

Three-way Calling



You can combine two, two-party calls into one three-way call. Follow the steps below for making three-way calls.

Making a Three-way Call

1. Follow the steps for "Making a Call" on page 27 or "Answering a Call on page 28.

2. While your call is in-progress with the first participant, dial the second phone number.

Note: If the dial pad is turned off, touch  **Dial Pad** before dialing the second number. See “Call Screen Layout” on page 86. for more information.

3. Touch . When the second participant answers, the second call is connected.
4. Touch  **Dial Pad** and then touch . The call becomes active with three participants.

Making Calls Using Contacts

Contacts are entries that you create to store names, numbers, and other information for people or groups of interest. If you've already entered information into your Contacts list, you can recall and dial the contact easily. For more information, refer to “Adding a Contact” on page 39.

1. From the Home screen, touch  **Contacts**.

Note: Before the CONTACT LIST is opened, you will see the following notification screen: **TOUCH GREEN ICON  ON THE RIGHT SIDE TO CALL.** Touch “OK” to continue, or touch “Don't Show Again” to keep this notification from appearing again after you continue.





If you press the green phone button to the right of the Contact name on the **CONTACT LIST** screen, a call will be placed to that number.

2. To see all phone numbers for a contact, touch the name of the contact to open the **VIEW CONTACT** screen. Touch the desired phone number (mobile, home, work) to dial.
3. Touch the name of the contact. Touch the desired phone number (mobile, home, work, etc.) to dial.

Note: If the desired phone number is not visible, use the scrolling method to view additional phone numbers.

Note: To quickly locate a name with the slide closed, touch the “**Touch Here to Find**” area under the **CONTACT LIST** heading. Use the touch keypad or slide out the QWERTY keyboard to enter the first letter, or first two letters if necessary, of the contact's name and touch .

Answering a Call

When you receive an incoming call, touch  or the animated phone icon  (or touch the caller's Picture ID, if shown) on your touch screen to answer the call, or touch  to send the call to voicemail. Touch  or press the  **Volume key** to silence the ringer.

Answering Call-Waiting Calls

When you receive a call while on a call:

- Touch **ANSWER** or the animated phone icon  (or touch the caller's Picture ID, if shown) on your touch screen to answer the incoming call, while the original caller is placed on hold.
- Touch **SWITCH** to return to your original call.

Call In-Progress Options

Access numerous menus and features even while in a call.

1. While in a call, touch **Options**. The following menu items appear in the display.
 - **New Call**: Opens the touch keypad for placing another call.
 - **Messaging**: Displays the Messages menu.
 - **Contacts List**: Opens Contact list to view your contacts.
 - **Recent Calls**: Displays your recent incoming, missed and outgoing calls.
 - **Bluetooth Menu**: Displays the Bluetooth menu.
 - **Main Menu**: Displays the Main menu.
 - **Notepad**: Opens the Notepad.
 - **Whisper Mode**: Increases the microphone to the maximum volume level.

Note: During a call, turn on Whisper Mode when speaking softly or when the caller cannot hear your voice clearly. This mode is useful in meetings or public places.

2. Touch an option to open the highlighted menu or to activate the feature.
3. Touch **Mute** to mute the call. Touch again to unmute the call.
4. Touch **Spkr On** to turn the speaker off. Touch again to turn the speaker on.

Note: If the call is disconnected while accessing the Call-In Progress Options, the options disappear from the display and the Glyde™ eventually returns to the Home screen.

Recent Calls



When you place, miss, or receive a call, information about the call is saved in Recent Calls, which is a listing of the different types of calls you missed, received or dialed, and a set of timers for these calls. These categories are listed below.

- **Missed**: Displays any missed calls.
- **Received**: Displays any received calls that were answered.
- **Dialed**: Displays all outgoing calls made from your Glyde™.

- **All:** Displays all missed, received, and outgoing calls made from your Glyde™.
- **View Timers:** Displays amount of time for: Last Call, All Calls, Received Calls, Dialed Calls, Roaming Calls, Transmit Data, Received Data, Total Data, Last Reset, Lifetime Calls, and Lifetime Data Counter.

Viewing Recent Call History

Recent Calls retains information such as the duration, date and time, and whether the call was missed, received or dialed. It also retains information about the timers that accrue data of these calls.

1. From the home screen, touch  **Menu**.
2. Touch  **Recent Calls**.
3. Touch the location (i.e. Missed, Received, Dialed or All) of the information.
4. Touch the desired number you want view.
5. The following call information displays:
 - **Call Type:** The title bar displays if the call is a missed, dialed, or received.
 - **Name:** If the caller is in your Contacts list, their name is listed here as well as the appropriate icon to indicate Mobile 1, Mobile 2, Home, Work, or Fax. This option only appears if the caller is in your Contacts list. If the caller is not in your Contacts list, No Name appears.

- **Number:** Displays the telephone number.
 - **Time:** The time of the call.
 - **Date:** The date of the call.
 - **Duration:** The duration of the calls made or received.
6. Touch  to display the following options:
 - **Save:** Save the number to your Contacts list.

Note: If the save option doesn't appear, that entry is already in your Contacts list.

- **Details:** Displays details about the caller if entered in Contacts.
 - **Erase:** Deletes the call from Call History.
 - **Lock/Unlock:** Locks or unlocks the entry to prevent accidental deletion.
 - **View Timers:** Select to view the call timers for your Glyde™.
7. Touch the option you want enter.

Call History Icons

When you view All Recent Calls, an icon to the left of the number indicates the type of call.



Indicates a received call that was answered.





Indicates a dialed call.



Indicates a received call that was missed.

Making Calls Using Call History

1. From the Home screen, touch  **Dial Pad**.
2. Touch **Recent**.
3. Touch the green phone icon  to the right of the number to dial.

Note: If the phone number is saved in your Contacts, the icon to the right of the number will be represented by the appropriate icon (**Mobile, Work, Home, etc.**)

Creating or Updating Contacts Using Call History

1. From the Home screen, touch  **Dial Pad**.
2. Touch **Recent**.
3. Scroll through the list of calls and touch the number to add to your Contact List or to update your Contact List.
4. Touch **Options** and select **1. Save**. The **Save** menu displays with two options:
 - **Add New Contact**
 - **Update Existing**

5. For **Add New Contact**, the following types are available:

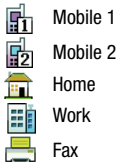

6. (If you selected **Update Existing**, proceed to step 14.)
7. Touch to highlight the desired entry type (**Mobile 1, Mobile 2, Home, Work, or Fax**).
8. To enter a name for the entry, touch the “Touch Here” field using the touch keypad or QWERTY keyboard. Touch **Abc** if you wish to select a different method of text entry, such as Word, Abc, ABC, 123, or Symbols. When you have completed entering the name, touch the appropriate number field (Mobile1, Mobile2, Home, Work, or Fax).
9. Enter the phone number for the contact. Continue to enter the numbers that you want to associate with the contact.
10. To assign the contact to a Group, touch Group and touch the desired category (No Group, Business, Colleague, Family, Friends).

Note: No more than 10 contacts may be added to any group.

11. To assign a **Speed Dial** location, touch the scroll bar to highlight the number you would like to assign. Touch  and select the **Set Speed Dial** option.
12. Touch an unassigned location. A confirmation message appears in the display. Touch **Yes** to add Contact to the speed dial location.



Note: Voicemail is assigned to Speed Dial location 1.

Note: You can assign a speed dial location to each number associated with the contact (Home, Work, Mobile 1, Mobile 2, and Fax.).



13. When you're finished entering information for the entry, touch . The entry is saved to your Contacts List.
14. If you selected **Update Existing** from the Recent Calls list, a list of existing contacts displays. Select the contact to update from the list.

15. On the Update Existing screen, touch the field to update. The Edit Contact screen displays. The information from the recent call is entered in the selected field. While you are on this screen, you may also update other fields. When finished, touch .

Deleting Call History Entries

1. From the Home screen, touch  **MENU**.
2. Touch  **Recent Calls**.
3. Touch the call category where you want to erase an entry (Missed, Received, Dialed, or All).
4. Find the entry that you want to delete and touch it.
5. Touch  and select **2. Erase**.
6. At the confirmation dialogue screen, touch **Yes** to erase the entry or **No** to abort the erase action.

Deleting All Call History Entries

1. From the Home screen, touch  **MENU**.
2. Touch  **Recent Calls**.

3. Touch the call category where you want to erase entries (Missed, Received, Dialed, or All). Do not touch any entry in the list.
4. Touch  and select **1. Erase All**.
5. At the confirmation dialogue screen, touch **Yes** to erase the entry or **No** to abort the erase action.

Roaming

What is Roaming?

Your Glyde™ can roam on other compatible digital networks. Roaming occurs when you travel outside a pre-designated coverage area. The roaming icon  displays when roaming is active. Extra charges may apply when making or receiving calls.

Note: Some features may be unavailable while roaming.



Roaming Options

The following roaming options are available:

- **Home Only** - Your Glyde™ is available for normal operation only in the designated coverage area.
- **Automatic:** The preferred roaming list is used to acquire service.



Note: Contact Verizon Wireless for information regarding preferred systems.

To change your Roaming option, follow these steps:

1. From the Home screen, touch  **MENU**.
2. Touch  **Settings & Tools**.
3. Touch **7. Phone Settings**.
4. Scroll the screen up and touch **7. System Select**. To make your selection, touch **Home Only** or **Automatic** roaming option.

TTY

Your Glyde™ is fully TTY compatible. Connect the TTY equipment to the headset jack, which is located on the top of your Glyde™. Before you can use your Glyde™ with a TTY device, you'll need to enable TTY functions in the Glyde™.

1. From the Home screen, touch  **MENU**.
2. Touch  **Settings & Tools**.
3. Scroll the screen up and touch **8. Call Settings**.
4. Touch **3. TTY Mode**. The TTY Mode screen displays.
5. A warning appears in the display stating **“ENABLING TTY WILL DISABLE HEADSET AUDIO. CONTINUE?”**

Touch **Yes** to proceed to TTY MODE screen. Touch **No** to return to **Call Settings** menu.



6. Touch to select one of the following options:

- **TTY Full**
- **TTY + Talk (VCO)**
- **TTY + Hear (HCO)**
- **TTY Off**

The **TTY MODE SET** confirmation screen displays.

Voice Commands

Voice Commands is advanced speech recognition software that can be used to activate a wide variety of functions on your Glyde™. Voice Commands software automatically voice activates all contacts for voice dialing and searching, no pre-recording or training needed. Speak phone numbers naturally to dial, and use voice commands to navigate phone menus.

1. From the Home screen, touch  **My Shortcuts**.
2. Touch  **Voice Commands**.

The following is a list of functions you can perform using Voice Commands speech recognition on your phone.



- **Call <Name or #>**: Dial by saying a Name in your Contacts List, a Name and a Location (home, work, mobile) or the phone number.
- **Send <Msg Type>**: Send a text, picture, or video message to a number or to someone in your Contacts List.
- **Goto <Menu>**: Open any application installed on your device.

- **Check <Item>**: Provides details of your phone status, voicemail, messages, missed calls, time, signal strength, battery level, and volume level.
- **Contacts <Name>**: Open the contact record for a matched name in your Contacts List.
- **Play <Playlist>**: Opens the My Music menu, or plays songs in a playlist or all songs if requested.
- **My Account**: Provides information about your Verizon Wireless account.
- **Help**: Provides a helpful tutorial on how to use Voice Commands.

Call <Name or #>

Digit Dial allows you to dial any phone number by simply speaking the digits into the Glyde™. No training is necessary, and Digit Dial is programmed to understand natural speech.

Note: You may need to train the speech recognition to understand Contact names that you speak.

1. From the Home screen, touch  **My Shortcuts**. Touch  **Voice Commands**.
2. After a brief pause, a list of optional commands appears in the display and the audio prompt "Please say a command" plays through the speakerphone. Say "Call" at a distance of 3-12 inches from the phone in a natural voice.

3. "Please say the name, number, voice mail or last number" plays through the speaker.
4. To use Digit Dialing, say the area code and number you want to dial into the microphone, clearly and naturally.

-or-

To use Name Dialing, say the name of one of your Contacts you want to dial.

Note: The entry for Name Dialing must be stored in your Contact list.

5. The number or name you said is repeated through the speaker and your phone dials the number.
6. If Voice Commands is not sure of the number you said, a list of possible matches appears in the display.
7. You're asked to confirm the correct number as Voice Commands displays the results.
 - Say "**Yes**" to confirm the number.
 - Say "**No**" to reject the number.
 - Say "**Exit**" to exit the Voice Command.
 - Say "**Repeat**" to have the selected number read one more time.

Note: In case various numbers are displayed, "**Which Number?**" will display in the **Listening** menu option.

8. The location is repeated through the speaker and your phone dials the number.

Send <Msg Type>

Send Text, Picture or Video

Use the following steps to send a text, picture or video message with Voice Commands.

1. From **My Shortcuts** menu, touch  **Voice Commands**.
2. A list of commands appears in the display and the audio prompt "Please say a command" plays through the speakerphone, if it is enabled.
3. Say "Send Text" or "Send Picture" or "Send Video" at a distance of 3-12 inches from the microphone. "Please say the name or number" plays through the speakerphone.
4. Say the name exactly as it is displayed in your Contacts list, or say the phone number of the recipient.

Note: In case various numbers are displayed, “Which Number?” will display in the **Listening** menu option.

5. The contact name or number appears in the To: field. For more information on how to complete the text, picture or video message, see “*Creating and Sending Text Messages*” on page 57, “*Creating and Sending Picture Messages*” on page 58 or “*Creating and Sending Video Messages*” on page 60.

Goto <Menu>

The “Go To” command allows you to access a menu within the Glyde™ (for example, “Go to Contacts”). If no menu option is stated, a list of options will be provided.

Opening Menus and Applications

To begin navigation of menu items on your Glyde™ or to open select applications using Voice Commands, perform the following:

1. From **My Shortcuts** menu, touch  **Voice Commands**.
2. A list of commands appears in the display and the audio prompt “Please say a command” plays through the speakerphone.

3. To begin navigation of menu items, say “Go To” at a distance of 3-12 inches from the microphone. The menu list displays and a prompt of “Please choose” plays through the speakerphone.
4. Select one of the following menus or applications: **Contacts, Recent Calls, Messaging, Get It Now, Settings & Tools, Internet Browser, V CAST Videos** or **My Music**. The option spoken opens.

Check <Item>

Checking Phone Status

1. From **My Shortcuts** menu, touch  **Voice Commands**.
2. A list of commands appears in the display and the audio prompt “Please say a command” plays through the speakerphone.
3. Say “Check” at a distance of 3-12 inches from the microphone. “Please choose” plays through the speakerphone. Valid “Check” commands are:
 - **Status:** Displays and announces all of the available status indicators in sequence.
 - **Voicemail:** Displays the number of new voicemail messages.

- **Messages:** Displays and announces the number of new voicemail, TXT, and Picture messages.
 - **Missed Calls:** Displays the missed call log.
 - **Time:** Displays and announces the current time.
 - **Signal Strength:** Displays and announces the current EVDO and 1x signal strength levels.
 - **Battery:** Displays and announces the current battery level.
 - **Volume:** Displays and announces the current master volume setting.
4. The option spoken opens.

Contacts <Name>

To perform a name lookup, you'll need to have some entries in your Contacts list.

1. From **My Shortcuts** menu, touch  **Voice Commands**.
2. A list of commands appears in the display and the audio prompt "Please say a command" plays through the speakerphone.
3. Say "Lookup" or "Contacts" at a distance of 3-12 inches from the microphone. "Please say the name" plays through the speakerphone.

4. Say the name exactly as it is displayed in your Contacts list. The contact name appears in the display with other information that you've entered for that contact.

Play <Playlist>

Play

Play launches the **My Music** menu screen. Options are listed in the following order:

Genres, Albums, Playlist, Play All, Artists, Songs, Inbox and Shuffle.

1. From **My Shortcuts** menu, touch  **Voice Commands**. A list of commands appears in the display and the audio prompt "Please say a command" plays through the speakerphone.
 - If you say "Play", the **My Music** menu launches.
 - If you say "Play" followed by a playlist name, songs on the playlist will begin to play.
 - If you say "Play All", all songs will play in alphabetical song title order.

My Account

Using Voice Commands, you can check your Verizon Wireless account status by voice command.

Note: This feature launches the browser to your account page, and requires a data plan and is subject to Verizon Wireless data coverage.

1. From **My Shortcuts** menu, touch  **Voice Commands**. A list of commands appears in the display and the audio prompt "Please say a command" plays through the speakerphone.
2. Say, "My Account" at a distance of 3-12 inches from the phone in a natural voice.
3. The phone's mobile web browser will launch and display your account information. For details on using your browser, see "*Browser*" on page 114

Help

Provides helpful information on how to use Voice Commands.

1. From **My Shortcuts** menu, touch  **Voice Commands**. A list of commands appears in the display and the audio prompt "Please say a command" plays through the speakerphone.
2. Say, "Help" at a distance of 3-12 inches from the phone in a natural voice. The tutorial appears in the display.

Section 5: Understanding Your Contacts

This section allows you to manage your daily contacts by storing their name and number in your Address Book.

Contacts Icons

The following table shows the various contact icons.



Mobile 1 icon. Enter a mobile number for the entry in this field.



Home icon. Enter a home number for the entry in this field.



Work icon. Enter the work number for the entry in this field.



Email 1 icon. Enter an Email address for the entry in this field.



Group icon. Select an available group to associate with the entry in this field.



Picture icon. Select an available pre-loaded image or downloaded image from Picture ID to associate with the contact.



Ringtone icon. Select a ringtone to associate with the entry in this field.



Mobile 2 icon. Enter a secondary mobile number for the entry in this field.



Fax icon. Enter a fax number for the entry in this field.



Email 2 icon. Enter a secondary Email address for the entry in this field.





Note icon. Enter a note for the entry in this field.



Adding a Contact

When you add information to your Contacts, you can add it as a new entry or as an existing entry.

Method 1

Creating a new Contact from the Home screen

1. From the Home screen, touch  **Contacts**.
2. Touch .
3. Touch the **Name** input field. Enter a name for the entry using the touch keypad or the QWERTY keyboard. After entering the name, touch .

4. Touch the appropriate field (**Mobile 1, Home, Work, Email 1,** etc.) to input a number. Once highlighted, use the touch keypad or QWERTY keyboard to enter required information. Scroll to highlight other type fields, if desired.
5. To assign a **Speed Dial** location after entering the number, touch . Touch **1. Set Speed Dial**.
6. Touch an unassigned location. A confirmation message appears. Touch **Yes** to add the Contact to the speed dial location. Touch **No** to stop the process. Touch  to exit the Speed Dial field.

Note: Voicemail is assigned to Speed Dial location 1.



Note: You can assign a speed dial location to each number associated with the contact (Home, Work, Mobile 1, Mobile 2, and Fax.).

7. When you're finished entering information for the entry, touch  to save the entry to your Contacts.

Method 2

Adding a number to a new or existing Contact from the Home screen

You can add new numbers to the Contacts by simply entering the number into the Dial Pad, then following the necessary prompts to complete the process.

1. From the Home screen, touch  **Dial Pad**.
2. Enter the phone number using the touch keypad or QWERTY keyboard, then touch .
3. Touch **1. Save**.

You're prompted to select from **Add New Contact, Update Existing, or Notepad**.

4. Touch **1. Add New Contact** to enter the number as a new contact, touch **2. Update Existing** to update an existing contact, or touch **3. Notepad** to save the entry to a new note.

Note: If you saved the entry in Notepad, the number can be viewed in Notepad under Settings & Tools. For more information, refer to "Notepad" on page 112.

5. If you selected **Update Existing**, proceed to Step 11. If you selected Notepad, proceed to step 14.

6. If you selected **Add New Contact**, the following types are available.

-  Mobile1
-  Mobile2
-  Home
-  Work
-  Fax

7. Touch the desired entry type (**Mobile 1**, **Mobile 2**, **Home**, **Work**, etc.).

8. Touch the **Name** field to enter a name for the entry using the touch keypad. Touch **Abc** if you wish to select a different method of text entry, such as Word, Abc, ABC, 123, or Symbols. Touch **DONE** to exit the Name field.

9. To assign a **Speed Dial** location, touch the number you would like to assign to a **Speed Dial** location and touch **Options**. Touch **Set Speed Dial**.

Touch an unassigned location. A confirmation message appears. Touch **Yes** to add Contact to the speed dial location. Touch **DONE** to exit the Speed Dial field.

Note: Voicemail is assigned to Speed Dial location 1.



Note: You can assign a speed dial location to each number associated with the contact (Home, Work, Mobile 1, Mobile 2, and Fax.).

10. When you're finished entering information for the entry, touch **SAVE**. The entry is saved to your Contacts.

11. If you selected **Update Existing**, the Contact List opens. Touch the name of the entry to update, or touch the "Touch Here to Find" field to access the touch keypad. Using the touch keypad or QWERTY keyboard, enter enough letters to identify the entry and touch **DONE**. Once you've located the entry to update, touch the entry to access the Update Existing display.



12. Touch the desired contact number type to store the number.

13. Touch **SAVE** to save the updated entry.

14. If you selected Notepad, the Notepad opens with the phone number entered into the **ADD NEW NOTE** screen. Type in any additional text and touch  to save it.
15. Go back to Step 4 if you also want to add this number to a new or existing contact, or press the  **Home** key to return to the Home screen.

Adding Pauses

Calls to automated systems often require a password or account number. Instead of manually entering numbers each time, store the numbers to your Contacts along with special characters called pauses.

1. From the Home screen, touch  **Dial Pad**.
2. Enter the phone number up to where you want to add the pause. Wait using the touch keypad, then touch .
3. Touch **2. Wait** (a “w” appears in the display) or **3. 2-Sec Pause** (a “p” appears in the display).
 - **Wait:** A hard pause stops the calling sequence until further input from you.
 - **2-Sec Pause:** A two-second pause stops the calling sequence for two seconds and then automatically sends the remaining digits.
4. After your entry, touch , then **1. Save**.

5. Continue with Method 2, Step 4 for **Adding a number to a new or existing Contact from the Home screen**.



Note: Entering multiple Add Pauses extends the length of a pause. For example, two consecutive Add Pauses cause a total pause time of four seconds. Keep in mind pauses count as digits towards the 48-digit maximum.

Contact Groups

You can place Contact entries into categories, called “**Groups**.” Groups allow you to search your Contacts faster, quickly send messages to one or more group members, and more.

Note: By default, new entries to your Contacts are placed into the No Group category unless a specific group category is selected.

View Groups

1. From the Home screen, touch  **MENU**.
2. Touch  **Contacts**.
3. Touch **3. Groups**. The following groups appear in the display:
 - No Group
 - Business
 - Colleague

- Family
- Friends

4. Touch the desired group.

Add a New Member to a Group

Once you have selected the desired group, you can add Contacts from your Contact List to that group, using the following procedure:

1. From the **Groups** menu, touch the group type.

The current members of that group display. If there are no members, a banner displays: **NO GROUP MEMBERS**.

2. Touch **ADD**, and the list of Contacts displays.
3. Touch the entry or entries to add to the group, then touch **DONE**.

The list of members of the Group display.

Note: A maximum of ten members can be assigned to a group.



Remove an Entry from a Group

1. From the **Groups** menu, touch the group type.

The current members of that group display.

2. Touch **Options**, then scroll to **6. Erase Members**.
3. Touch **6. Erase Members** and the current members of the Group display. To select a member to erase, touch the entry. A checkmark is added to the member.
4. When the member(s) to remove are selected, touch **DONE**. A confirmation message appears. Touch **Yes** to remove the entry; touch **No** to stop the process.



Move an Entry to Another Group

1. From the Home screen, touch  **MENU**. Touch  **Contacts**.
2. Touch **2. Contact List**. The Contact List displays.
3. Touch an entry in the Contact List and the information for that Contact displays. This includes the Group that the contact is assigned to.
4. Touch **EDIT**. The Edit Contact screen displays.
5. Scroll to locate the **Group** field and touch the entry field.
6. The following groups display:
 - No Group
 - Business

- Colleague
 - Family
 - Friends
7. Touch the desired group. “**CONTACT ADDED TO <name of group>**” confirmation message appears. The Edit Contact screen displays with the changed Group field.
 8. Touch **SAVE**. The contact information has been saved with the new Group information.

Create a New Group





In addition to the five groups already in your Samsung Glyde™, you can create additional groups (a maximum of 25). New group names must be within a 32-character limit.

1. From the Home screen, touch  **MENU**.
2. Touch  **Contacts**.
3. Touch **3. Groups**. Your existing groups appear in the display.
4. Touch **NEW**. The **NEW GROUP** screen displays.
5. Using the touchpad or the QWERTY keyboard, enter the name of the new group.
6. Touch **SAVE**. The Groups list now displays the new group added.

Send a Text Message to Members of a Group

Use Send Message in the Group feature to send a message to as many as 10 members of a group at once.

Note: Text messaging availability varies when roaming off the Verizon Wireless Network.

1. From the Home screen, touch  **MENU**.
2. Touch  **Contacts**.
3. Touch **3. Groups**. Your existing groups appear in the display. Touch the desired group name and touch  and touch **1. New TXT Msg**.
4. Touch the desired contact(s) in the group to send the text message. A checkmark will appear beside the contact's name(s).
5. Touch . The **NEW TXT MESSAGE** header displays.





Note: You can mark up to 10 members of a group for message distribution.

6. Touch the message field to activate the touch keypad and enter the content of your message using the touch keypad or the QWERTY keyboard and touch .

7. To send the text message, touch .

Send a Picture Message to Members of a Group

Note: Only available within Verizon Wireless Enhanced Services Area.

1. From the Home screen, touch  **MENU**.
2. Touch  **Contacts**.
3. Touch **3. Groups**. Your existing groups appear in the display.
4. Touch the desired group name and touch .
5. Touch **2. New Picture Msg**.
6. Touch the desired contact(s) in the group to send the picture message. A checkmark will appear beside the contact's name(s).
7. Touch .

Note: You can mark up to 10 members of a group for message distribution.





The **NEW PICTURE MSG** screen displays.

8. Touch the following entry fields:
 - **Text:** Add text to the Picture Message.

- **Picture:** Add an image from the My Pictures gallery to the message.
 - **Sound:** Add sound to the Picture Message.
 - **Subject:** Add a subject to the Picture Message.
 - **Name Card:** Attach a Name Card or an entry in your Contacts to the message.
9. Once you've finished adding the desired content to your Picture Message, touch .

Send a Video Message to Members of a Group

Note: Only available within Verizon Wireless Enhanced Services Area.

1. From the Home screen, touch  **MENU**.
2. Touch  **Contacts**.
3. Touch **3. Groups**. Your existing groups appear in the display.
4. Touch the desired group name and touch .
5. Touch **3. New Video Msg**.
6. Touch the desired contact(s) in the group to send the video message. A checkmark will appear beside the contact's name(s).
7. Touch .

Note: You can mark up to 10 members of a group for message distribution.

The **NEW VIDEO MSG** header displays.

Touch the following entry fields:

- **Text:** Add text to the Video Message.
 - **Video:** Add an image from the My Videos gallery to the message.
 - **Subject:** Add a subject to the Video Message.
 - **Name Card:** Attach a Name Card or an entry in your Contacts to the message.
8. Once you've finished adding the desired content to your Video Message, touch **SEND**.



Finding a Contact Entry

From the Home screen, you can quickly open the Contacts list.



1. From the Home screen, touch  **Contacts**.
2. Touch the "Touch Here to Find" field to access the touch keypad and enter the first and second letters of the name you wish to find and touch **DONE**. The contact name will appear at the top of the list.

Note: With the QWERTY keyboard open, the cursor will be placed in the **Find** field. You may enter part or all of the Contact name to see a filtered list.

Editing an Existing Contact Entry

1. From the Home screen, touch  **Contacts**.
2. Touch the desired contact list entry and touch **EDIT**.
3. Touch the name, number, Email address, or other field that you wish to edit.
4. Touch **Clear** to backspace and delete numbers, text, or symbols, or touch and hold **Clear** to erase everything in the highlighted field.
5. Use the touch keypad or QWERTY keyboard to re-enter numbers, text, or symbols.
6. When you're finished editing the entry, touch **DONE**.
7. Touch **SAVE** to save your changes.
8. Press the  **Home** key on the front of the phone to return to the Home screen.

Deleting a Contact Entry

1. From the Home screen, touch  **MENU**.
2. Touch  **Contacts**.



3. Touch **2. Contact List**. Touch the desired contact list entry.
4. Touch the **Options** and touch the **Erase** option.
5. A confirmation message appears. Touch **Yes** to delete the entry from the Contact List. Touch **No** to stop the process.

Speed Dialing

Speed dialing allows you to touch and hold a key (or keys) to dial the number associated with those key(s). There are three types of speed dialing; **1-touch**, **2-touch**, and **3-touch dialing**.



Note: 1-Touch, 2-Touch, and 3-Touch dialing allows you to call numbers stored in your Contact List quicker. Memory location 001 is reserved for voicemail.

1-touch dialing

Call phone numbers assigned to memory locations 002 - 009 by touching and holding the any of the 2 - 9 keys. For example, to speed dial the number assigned to location 2, touch  **Dial Pad** to access the touch keypad, then you must touch and hold  until the name and number appear in the display and the number is dialed.



2-touch dialing

Call phone numbers assigned to keys 010 through 099 by touching  **Dial Pad** to access the touch keypad, and briefly



touching the first key, then touching and holding the second key. For example, to speed dial the number assigned to 013, briefly touch , then touch and hold  until the number dials.

3-touch dialing

Call phone numbers assigned to memory locations 100 through 999 by touching  **Dial Pad** to access the touch keypad, and briefly touching the first and second keys, then touching and holding the third key.

For example, to dial location number 113, briefly touch  , then touch and hold  until the number dials.



Assign a speed dial location

1. From the Home screen, touch  **MENU**.
2. Touch  **Contacts**.
3. Touch **4. Speed Dials**. The Speed Dials screen displays with the first available number at the top of the list.
4. Touch the number you wish to assign or touch the **“Touch Here to Find”** field to go to the speed dial location by entering the location number using the touch keypad. The **SET SPEED DIAL** screen displays.
5. Touch the entry you want to assign to that speed dial location.

6. A confirmation message appears. Touch **Yes** to assign the entry to the Speed Dial list. Touch **No** to stop the process.
7. Continue to assign speed dial entries or press the  **Home** key on the front of the phone to return to the Home screen.

My Name Card

My Name Card allows you to create a virtual business card. Once completed, you can send the card to recipients as a vCard attachment.

1. From the Home screen, touch  **MENU**.
2. Touch  **Contacts**.
3. Touch **6. My Name Card**. The Edit My Name Card screen displays.
4. Touch each field, and enter information in the field as desired. Use the touch keypad or the QWERTY keyboard to enter information.
5. Touch  to exit from each field.

Note: A check mark appears to the left of selected contacts.

6. When finished, touch  to save the Name Card.



Sending Contact Information (vCard) to another Bluetooth-enabled phone

You can send individual contacts or your entire contact list to or from another device that is Bluetooth enabled*.

Note: *If Bluetooth is not powered on, or your Glyde™ is not paired with another device, see “Turning Bluetooth On or Off” on page 73.

Important: Not all Bluetooth devices will accept a name card.

1. From the Home screen, touch  **Contacts**.
2. Touch  and select **1. Send Name Card**. The following options display:
 - **TXT Message:** Allows you to send a name card via TXT Message. A name card with a picture cannot be sent in a TXT Message because it exceeds the maximum number of characters allowed.
 - **Picture Message:** Allows you to send a name card via Picture Message.
 - **Video Message:** Allows you to send a name card via Video Message.
 - **Bluetooth:** Allows you to send a name card to a Bluetooth-enabled device.
3. Touch **4. Bluetooth**.

4. Touch a contact name to select it, or touch  and **1**.
Mark All to select all contact names in the list (if sending via Bluetooth). A check mark will appear beside the contact's number. Touch .
5. Touch the destination device.

Note: If your Glyde™ is not paired already with the destination device, follow the instructions on p.90 for Bluetooth Search.

6. Touch  to connect to the other device. The “**CONNECT TO <DEVICE NAME>?**” prompt displays. Touch **Yes**.
7. Confirm the name card transfer by selecting the appropriate key on the other device if prompted.
8. When the information is exchanged, a message will appear that the transfer is complete.

Note: ** All information will be transferred except for group name, ringtone, and Emergency contact reference.

Finding My Phone Number



My Number displays the ten-digit number assigned to your Glyde™.

1. From the Home screen, touch  **MENU**.

2. Touch  **Settings & Tools**.
3. Scroll the screen up and touch **0. Phone Info**.
4. Touch **1. My Number**. The mobile device, phone number, and mobile identification number are displayed.

Emergency Contacts

Assigning an Emergency Contact - From Contacts

1. From the Home screen, touch  **MENU**.
2. Touch  **Contacts**.
3. Touch **5. Emergency Contacts**. The Emergency Contacts screen displays **Contacts 1**, **Contacts 2**, **Contacts 3** and **Personal Info**.



Note: Use the **Personal Information** option to enter information such as illnesses, allergies, and other detail information.

4. Touch either **Contacts 1**, **Contacts 2** or **Contacts 3**.
5. **1. From Contacts** and **2. New Contact** are displayed.
6. Touch **1. From Contacts** to add an emergency number from your contacts list. Touch a Contact to assign the contact.

Assigning an Emergency Contact with a New Contact

1. Repeat steps 1 through 4 in the previous section. See “Assigning an Emergency Contact - From Contacts” on page 49.
2. Touch **2. New Contact** to enter a new contact as an emergency number. Enter Contact information then touch . The Emergency Contact is added and is displayed in the Contact List in red font.

Unassigning an Emergency Contact

1. From the Home screen, touch  **MENU**.
2. Touch  **Contacts**.
3. Touch **5. Emergency Contacts**.
4. Touch the Emergency Contact to unassign.

Note: Emergency contacts are displayed in red font.

5. Touch  and touch **2. Unassign**.
The Emergency Contact screen displays with the contact removed.

Section 6: Selecting Text Entry Modes

This section outlines how to select the desired text input mode when entering characters into your Samsung Glyde™.

Changing Text Entry Mode with the Touch Keypad



1. While composing a message, touch  to access the **Entry Mode** menu. The following Entry Mode options display: Word, Abc, ABC, 123, Symbols, Domain Extensions* Quick Text**.

Note: *The Domain Extensions option is only available in the **To** field.

Note: **The Quick Text option is only available in the **Text** field to quickly enter text into a message.

2. Touch the desired text mode. The entry mode button will change to reflect the mode that you selected. For example, if you selected **1. Word**, the entry mode button will display .

Changing Text Entry Mode with the Slide-out Keyboard



1. While composing a message, press the  key to toggle from letters to yellow numbers/symbols on the QWERTY keyboard, or vice versa. When Function is ON to access numbers and symbols, the  icon will appear on the top annunciator line of the display.
2. When Function is OFF to access white letters, press the  key to change the entry mode between **Abc**, **ABC**, and **abc**.

Note: **Word** mode is not available from the slide-out QWERTY keyboard.

Creating a Text Message with the Touch Keypad

Entering Text Using ABC Mode

We will start our example by entering the email address USER987@Bogus.com in the **To** field.

1. From the Home screen, touch  **MENU**.
2. Touch  **Messaging**, then touch **1. New Message**.

3. Touch **1. TXT Message** to compose a new text message.
4. Touch the **To** field area to manually enter the Email address of the recipient.
5. Touch **123** and then touch **3. ABC**. You are returned to the **To** entry field in **ABC** mode.
6. Type the word "USER" by doing the following:
 - Touch **TUV** twice quickly so that "U" displays.
 - Touch **PQRS** four times quickly so that "S" displays.
 - Touch **DEF** twice quickly so that "E" displays.
 - Touch **PQRS** three times quickly so that "R" displays.

Note: If you make a mistake, touch **Clear** to erase the incorrect entry and try again.

Entering Numbers Using 123 Mode

Continuing our example from the previous section, **Entering Text Using ABC Mode:**

7. Touch **ABC** and then touch **4. 123**. You are returned to the **To** entry field in **123** mode.
8. Touch **9** **8** **7** to complete the first part of the email address.

Note: You can also access most numbers in **Abc/ABC/abc** mode by pressing the associated touch key quickly multiple times until the desired number displays.

Entering Text Using Symbols Mode

Continuing our example from the previous section **Entering Text Using 123 Mode:**

9. Touch **123** and then touch **5. Symbols**. You are returned to the **To** entry field in **Symbols** mode.
10. Touch the **@** symbol.

Note: You can also input the "@" symbol in **Abc/ABC/abc** mode by pressing **@** twice quickly.

Entering Text Using Word Mode

Continuing our example from the previous section, **Entering Text Using Symbols Mode:**

11. Touch **Symbols** and then touch **1. Word**. You are returned to the **To** entry field in **Word** mode.

12. Touch each of the following touch keys only once to enter the word "Bogus":



Note: Word recognizes that the most frequently used word for the sequence of keys touched. If more than one word shares the same sequence, Word provides the most common one. If Word does not display the word that you want, try touching **Next** to see the next possible match.

Entering Text Using Domain Extensions Mode

Continuing our example from the previous section, **Entering Text Using Word Mode**:

13. Touch **word**, scroll the screen up, and then touch **6. Domain Extensions**.
14. Touch ".com".
15. Touch **DONE**.

Entering Text Using Quick Text Mode

Continuing our example from the previous section, **Entering Text Using Domain Extensions Mode**:

16. Touch the **Text** field area, and then touch the **Abc** button.
17. Scroll the screen up and touch **6. Quick Text**. The QUICK TEXT screen displays. Choose the quick text phrase "What's up?" and then touch **SELECT**. You are returned to the **Text** field still in the **Abc** mode.

Note: You may also create your own quick text. While in the QUICK TEXT screen, touch **NEW**. Compose a quick text and touch **DONE**. Your new quick text is added to the top of the selection list.

18. Touch **DONE** to exit from the **Text** field.







Warning! Since this is just an example, please don't touch **SEND**. Instead, touch the **Home** key and touch "No" when prompted to SAVE MESSAGE?

Creating a Text Message with the Slide-out QWERTY Keyboard

Entering Text Using ABC Mode

We will start our example again by entering the email address USER987@Bogus.com in the **To** field.



1. Slide out the QWERTY keyboard. The display rotates from a vertical viewing mode to a horizontal viewing mode.

- From the Home screen, touch  **Messaging**, then press  for **1. New Message**.
- Press  for **1. TXT Message** to compose a new text message.
- The cursor will automatically be placed in the **To** field.
- Press the  key to turn off the function mode. (The  icon will disappear from the top line of the display.) You can now access letters on the keyboard.
- Press the  key to change from **Abc** to **ABC** mode.
- Type the word "USER".

Note: If you make a mistake, touch  to erase the incorrect entry and try again.

Entering Numbers Using 123 Mode

Continuing our example from the previous section, **Entering Text Using ABC Mode**:

- Press the  key again to access numbers on the keyboard. (The  icon will appear on the top line of the display.)

- Press    to complete the first part of the email address.



Entering Text Using Symbols Mode

Continuing our example from the previous section, **Entering Text Using 123 Mode**:

- Press the  key to enter the "@" symbol.

Entering Text Using Abc Mode





Continuing our example from the previous section: **Entering Text Using Symbols Mode**.



- Press the  key again to access letters on the keyboard. You are returned to **Abc** mode.
- Type "Bogus.com".
- Press the  **Enter** key to advance to the **Text** field.

Entering Text Using Quick Text Mode



Continuing our example from the previous section, **Entering Text Using Abc Mode**:

Note: To use Quick Text, you will need to use the touch screen for this part.

14. Press the  key again to access numbers on the keyboard. Touch the  button on the screen.
15. Scroll the screen up, and touch **5. Quick Text**, or press  on the QWERTY keyboard. The QUICK TEXT screen displays. Choose the quick text phrase "**What's up?**" and then touch . You are returned to the **Text** field still in **123/Sym** mode.

Note: You may also create your own quick text. While in the QUICK TEXT screen, touch . Compose a quick text and touch . Your new quick text is added to the top of the selection list.

16. Touch  to send the message.

Warning! Since this is a bogus example, please don't touch . Instead, touch the  **Home** key and touch "**No**" when prompted to SAVE MESSAGE?

Section 7: Messaging

This section allows you to send or receive different types of messages. It also includes the features and functionality associated with messaging.

NOTE: The QWERTY keyboard is recommended when creating text, picture and video messages. For information concerning the use of the QWERTY keyboard for messaging, See “Keyboard Navigation” on page 22.

Types of Messages



Your Samsung Glyde™ is capable of sending Email, text, picture and video messages. Send Email, Mobile Instant Messages (IM), text, picture, and video messages by simply entering the Email address or the phone number of the recipient in the **To: <.....>** or **Send To** field when creating a new message.

Retrieving New Messages

While text messages from other phones are delivered directly to your Glyde™, Picture and Video messages and Email will be stored in the Inbox of the message server and the server will alert you to new messages. Therefore you need to retrieve new Picture, Video and Email messages to your Glyde™.

Opening a Text Message

When you receive a message, the message ringer sounds, (unless turned off) and New Text Message appears in the display. The date and time of the message also appear in the display.

1. From the Home screen, touch  **MENU**.
2. Touch  **Messaging**.
3. Touch **2. Inbox**. The Incoming messages display.
4. Touch the message to read. The message information displays.
5. With the message open, touch . The following options are available:
 - **Call:** allows you to call the messaging phone back.
 - **Forward:** allows you to forward the message to another phone.
 - **Erase:** allows you to erase the message from the Inbox.
 - **Reply W. Copy:** allows you to send a reply, with a copy of the received message.
 - **Save Quick Text:** allows you to save the text as quick text.
 - **Lock/Unlock:** allows you to lock (prevent the message from being erased) or unlock (allows the erasure of the message).

- **Add To Contacts:** allows you to add the sending number to your Contacts list.
 - **Erase Inbox:** allows you to erase all unlocked messages from the Inbox.
 - **Extract Addresses:** allows you to extract addresses from the phone message, and saves them to your Contact List.
 - **Messaging Font Size:** allows you to set the messaging font size to Normal, Small, or Large.
 - **Message Info:** allows you to see information such as the number, date and time of message, priority, message type, and size.
6. With the message open, touch **REPLY** to send a plain reply, or touch **Options** and select **REPLY W. Copy** to return a message to the sender.

Creating and Sending Text Messages

You can send text messages to another mobile phone or to an Email address.

Note: The QWERTY keyboard is recommended for creating text messages.

1. With the slide open from the Home screen, touch  **Messaging**.
2. Touch **1. New Message**.
3. Touch **1. TXT Message**.



4. Use the QWERTY keyboard to enter the phone number or Email address of the recipient, or touch the **Contacts** button  (to the right of the **To** field) to select up to 10 contacts as recipients.

Note: You can touch the  button to the right of the **To** field to select contacts as recipients.



5. While in the **To** field, touch **123/Sym** to change Text Entry Mode. Choose **Abc**, **ABC**, **123**, **Symbols** and **Domain Extensions** modes of text entry, or press  key to switch from yellow numbers/symbols to white letters on the QWERTY keyboard.
6. Touch **Add** to add a recipient From **Contacts**, **Recent Calls** or **Groups**. and touch **DONE**.

Note: If you do not select an option, touch **Back** to return to the message.

7. If necessary, press the  **Enter** key to advance to the **Text** field.

- Type in your message using the QWERTY keyboard. Press  key to switch between **Abc** and **123/Sym** mode. Press  key to switch between **Abc**, **ABC**, and **abc** modes.
- You may touch  then touch **2. Add** to add any of the following:
 - Add Quick Text:** Choose from up to 12 pre-loaded messages.
 - Add Graphic:** Lists preloaded and downloaded graphics.
 - Add Animation:** Lists preloaded and downloaded animations.
 - Add Sound:** Lists preloaded and downloaded sounds.
 - Add Name Card:** Attach My Name Card information or information from one of your Contacts.

Note: If you do not select an option, touch  to return to the message.

- Touch the item to Add, and touch  to attach it to your message.
- Before you send your message, you may access  for the entire text message:
 - Save As Draft:** saves the message, including recipient, as a draft message.

- Add:** Allows you to add Add Quick text, Add Graphic, Add Animation, Add Sound and Add Name Card to the message.
- Edit Text Format:** Allows you to edit the text size, alignment, style, color, and background color.
- Priority Level:** allows you to set the priority for the message.
- Callback #:** allows you to turn On or Off the callback number.
- Enh. Delivery Ack:** allows you to set the enhanced delivery acknowledgement to On or Off.
- Cancel Message:** allows you to cancel the message without sending or saving it to drafts.

- To send the message, touch .

Creating and Sending Picture Messages

Note: Only available within Verizon Wireless Enhanced Services Area.



Picture Message combines text, picture, and sound creating an intuitive message. This is also known as Multimedia Messaging (MMS).

Note: The QWERTY keyboard is recommended for creating picture messages.

- With the slide open from the Home screen, touch  **Messaging**.
- Touch **1. New Message**.

3. Touch **2. Picture Message**.
4. Use the QWERTY keyboard to enter the phone number or Email address of the recipient, or touch the **Contacts** button  (to the right of the **To** field) to select up to 10 contacts as recipients.



Note: You can touch the  button to the right of the **To** field to select contacts as recipients.

While in the **To** field, touch  to change Text Entry Mode. Choose **Abc**, **ABC**, **123**, **Symbols** and **Domain Extensions** modes of text entry, or press  key to switch from yellow numbers/symbols to white letters on the QWERTY keyboard.











5. Touch  to add a recipient From **Contacts**, **Recent Calls** or **Groups**, or to send the picture To **Online Album**.

Note: If you do not select an option, touch  to return to the message.

6. If necessary, press the  **Enter** key to advance to the **Text** field.

7. Type in your message using the QWERTY keyboard. Press  key to switch between **Abc** and **123/Sym** mode. Press  key to switch between **Abc**, **ABC**, and **abc** modes.
8. You may touch  on the screen to **Add Quick Text**.



Note: If you do not select an option, touch  to return to your message.

9. Press  key if necessary and press  to advance to the **Picture** field. Touch  to access **MY PICTURES** folder. Touch the desired picture and press  to attach the image.
10. In the **Sounds** field, touch  to access **MY SOUNDS** folder. Touch the desired sound to attach the audio clip and press  to attach the audio clip.
11. In the **Subject** field, enter the subject line using the QWERTY keyboard. You may touch  to **Add Quick Text**.
12. Press  key if necessary and press  to advance to the **My Name Card** field. Touch  to select **My Name Card** or an entry from your **Contacts** list.
13. Once all fields are complete, touch  to send the message to the intended recipient(s).



Creating and Sending Video Messages

Video Message combines text, and video creating an intuitive message. This is also known as Multimedia Messaging (MMS).

Note: The QWERTY keyboard is recommended for creating video messages.





1. With the slide open from the Home screen, touch  **Messaging**.
2. Touch **1. New Message**.
3. Touch **3. Video Message**.
4. Use the QWERTY keyboard to enter the phone number or Email address of the recipient, or touch the **Contacts** button  (to the right of the **To** field) to select up to 10 contacts as recipients.

Note: You can touch the  button to the right of the To field to select contacts as recipients.











5. While in the **To** field, touch  to change Text Entry Mode. Choose **Abc**, **ABC**, **123**, **Symbols** and **Domain Extensions** modes of text entry, or press  key to switch from yellow numbers/symbols to white letters on the QWERTY keyboard.

6. Touch  to add a recipient **From Contacts**, **Recent Calls** or **Groups**, or to send the video **To Online Album**.

Note: If you do not select an option, touch  to return to the message.

7. If necessary, press the  **Enter** key to advance to the **Text** field.
8. Type in your message using the QWERTY keyboard. Press  key to switch between **Abc** and **123/Sym** mode. Press  key to switch between **Abc**, **ABC**, and **abc** modes.
9. You may touch  on the screen to **Add Quick Text**.





Note: If you do not select an option, touch  to return to the message.

10. Press  key if necessary and press  to advance to the **Video** field. Touch  to access **MY VIDEOS** folder. Touch the desired video to attach the video clip. The video will play. Touch  to attach the video or touch  to cancel and return to **MY VIDEOS** folder.
11. In the **Subject** field, enter the subject line using the QWERTY keyboard. You may touch  to **Add Quick Text**.
12. Press  key if necessary and press  to advance to the **My Name Card** field. Touch  to select **My Name Card** or an entry from your **Contacts** list.
13. Once all fields are complete, touch  to send the message to the intended recipient(s).



Receiving Picture Messages

When you receive a new Picture Message, your Glyde™ will attempt to connect to the messaging server and download the picture or video attachment. If it cannot, you may access the message, and attempt to manually download the message and attachments.

Note: For the option **Reject** to appear in the display when you receive a Picture Message, Auto Receive mode must be set to Off in the Message Settings menu. The default Auto Receive value is set to On.

1. From the Home screen, touch  **MENU**.
2. Touch  **Messaging**.
3. Touch **2. Inbox**.
4. Touch the message to open.
5. Touch  to mute the attached sound byte if desired or you can touch . The following options may appear in the display:
 - **Reply:** Replies to the received message.
 - **Call:** Places a call to the sender of the text message.
 - **Play Again:** Replays the sound byte attached to a Picture Message.
 - **Forward:** Forward the message to another recipient.
 - **Erase:** Deletes the message. Only displays in menu when a sound byte isn't attached to the message that was sent.
 - **Save Pic/Video:** Saves the picture in a Picture message to My Pictures.
 - **Save As Ringtone:** Saves the sound byte received with the message as a ringtone.
 - **Save Sound:** Saves the sound received with the message.

- **Save Quick Text:** Saves the text received in the message to the Quick Text list.
- **Save Name Card:** Saves the attached name card to your Contact List.
- **Lock/Unlock:** Locks or unlocks the entry to prevent accidental deletion.
- **Add To Contacts:** Save the number of the sender to your Contacts as a new entry or add to an existing entry.
- **Erase Inbox:** Displays options to either erase All Messages or Only Read messages.
- **Message Info:** Provides the following information: From and Callback #, Priority, Message Type, Size and Attachment(s) name and size.

Note: When viewing a Picture message, you can view the previous Picture message by touching the  left arrow button. To view the next Picture message, touch the  right arrow button.

Receiving Video Messages

When you receive a new Video Message, your Glyde™ will attempt to connect to the messaging server and download the picture or video attachment. If it cannot, you may access the message, and attempt to manually download the message and attachments.

Note: For the option Reject to appear in the display when you receive a Video Message, Auto Receive mode must be set to Off in the Message Settings menu. The default Auto Receive value is set to On.

1. From the Home screen, touch  **MENU**.
2. Touch  **Messaging**.
3. Touch **2. Inbox**.
4. Touch the message to open.
5. Touch  to mute the attached sound byte if desired or you can touch . The following options may appear in the display:
 - **Call:** Places a call to the sender of the text message.
 - **Play:** Plays the sound byte attached to a Picture Message.
 - **Forward:** Forward the message to another recipient.
 - **Erase:** Deletes the message. Only displays in menu when a sound byte isn't attached to the message that was sent.
 - **Save Pic/Video:** Saves the video as a picture in to My Pictures.
 - **Save Quick Text:** Saves the text received in the message to the Quick Text list.
 - **Save Name Card:** Saves the attached name card to your Contact List.

- **Lock/Unlock:** Locks or unlocks the entry to prevent accidental deletion.
- **Add To Contacts:** Save the number of the sender to your Contacts as a new entry or add to an existing entry.
- **Erase Inbox:** Displays options to either erase All Messages or Only Read messages.
- **Message Info:** Provides the following information: From and Callback #, Priority, Message Type, Size and Attachment(s) name and size.



Note: When viewing a Video message, you can view the previous Video message by touching the  left arrow button. To view the next Video message, touch the  right arrow button.

Receive Messages While in a Call

1. When you receive a message while in a call, the **NEW TXT MESSAGE** or **NEW PIC-VIDEO MSG(S)** dialog box appears in the display. Touch **View Now** or touch **View Later**.

Note: Text messages can only be viewed during a call. Picture-Video messages can not be downloaded during a call.

2. If you touched **View Now**, the message displays. Touch  to reply.

3. When you touch  or , the screen re-displays the call information.

View a Picture-Video Message Later

1. When you receive a new Picture-Video message that you would like to view later, touch **View Later**. To view the message, touch  **MENU**.
2. Touch  **Messaging**.
3. Touch **2. Inbox** and touch the unopened message.



Message Folders

Your Glyde™ provides default message folders for your Text and Picture-Video messages.

Note: To quickly view all messages in the Inbox, Sent, or Drafts folders, open one message and then touch the  left arrow button the previous message. To view the next message, touch the  right arrow button.

Inbox

Received messages of all types are stored in the **Inbox** folder.

1. From the Home screen, touch  **MENU**.
2. Touch  **Messaging**.
3. Touch **2. Inbox**.

4. Touch the message that you wish to view. The contents of the message display.

5. While viewing a message, touch **Options** to display the available options. Options are dependent on the message type:

- **For Text Messages** the following options may appear in the display:

- **Call:** Places a call to the sender of the text message.
- **Forward:** Forwards the message to another recipient.
- **Erase:** Deletes the message. Only displays in menu when a sound byte isn't attached to the message that was sent.
- **Reply w. Copy:** Replies to the received message with a text message, picture message or video message and allows you to send a copy of the message to another contact.
- **Save Quick Text:** Saves the text received in the message to the Quick Text list.
- **Lock/Unlock:** Locks or unlocks the entry to prevent accidental deletion.
- **Add To Contacts:** Save the number of the sender to your Contacts as a new entry or add to an existing entry.
- **Erase Inbox:** Erases all messages in the Inbox.
- **Extract Addresses:** Extracts the number of the sender to your Contacts as a new entry or adds it to an existing entry.

- **Messaging Font Size:** Allows you to select the font size of the message being viewed. Select Normal, Small, or Large.

- **Message Info:** Provides the following information: From (also provides the date and time the message was sent), Callback #, Priority, Message Type, Size and if a Picture, Sound or Name Card were included in the message.

- **For Picture Messages** the following options may appear in the display:

- **Reply:** Replies to the received message.
- **Call:** Places a call to the sender of the text message.
- **Play Again:** Replays the sound byte attached to a Picture Message.
- **Forward:** Forwards the message to another recipient.
- **Erase:** Deletes the message. Only displays in menu when a sound byte isn't attached to the message that was sent.
- **Save Pic/Video:** Saves the picture sent in a Picture message to **My Pictures**.
- **Save As Ringtone:** Saves the sound byte received with the message as a ringtone.
- **Save Sound:** Saves the sound byte received with the message in **My Sounds**.
- **Save Quick Text:** Saves the text received in the message to the **Quick Text** list.
- **Save Name Card:** Saves the attached name card to your Contact List.
- **Lock/Unlock:** Locks or unlocks the entry to prevent accidental deletion.

- **Add To Contacts:** Save the number of the sender to your Contacts as a new entry or add to an existing entry.
- **Erase Inbox:** Displays options to either erase All Messages or Only Read messages.
- **Message Info:** Provides the following information: From (also provides the date and time the message was sent), Callback #, Priority, Message Type, Size and if a Picture, Sound or Name Card were included in the message.

Note: If no sound byte is attached to the message, touch **Erase** to delete the message. Touch **Mute/Unmute/Play** to play or mute/unmute the sound byte attached to the message.

- **For Video Messages** the following options may appear in the display:
 - **Call:** Places a call to the sender of the text message.
 - **Play Again:** Replays the video.
 - **Forward:** Forwards the message to another recipient.
 - **Erase:** Deletes the message. Only displays in menu when a sound byte isn't attached to the message that was sent.
 - **Save Pic/Video:** Saves the video received with the message to My Videos.
 - **Save Name Card:** Saves the attached name card to your Contact List.
 - **Lock/Unlock:** Locks or unlocks the entry to prevent accidental deletion.

- **Add To Contacts:** Save the number of the sender to your Contacts as a new entry or add to an existing entry.
- **Erase Inbox:** Displays options to either erase All Messages or Only Read messages.
- **Message Info:** Provides the following information: From (also provides the date and time the message was sent), Callback #, Priority, Message Type, Size and if a Picture, Sound or Name Card were included in the message.

6. Touch **REPLY** to reply to the message.



Note: When the Inbox exceeds 100 text messages, the first message in the list is replaced with the next incoming message. Picture messages are replaced when a maximum of 500 is reached. For information on how to set Auto Erase and Auto Receive, see “*Changing Message Settings*” on page 69.

Sent

Your Glyde™ stores messages in the **Sent** folder, regardless of whether the message was successfully transmitted. Verify if and when a message or Email was successfully transmitted by enabling the **Enh. Delivery Ack** feature in Message Settings.

Note: Enhanced Delivery Acknowledgement can't be set for a Picture-Video message.

Review Messages in the Sent Folder

1. From the Home screen, touch  **MENU**.
2. Touch  **Messaging**.
3. Touch **3. Sent**.
4. Touch the message you wish to review.
5. While viewing the message, touch  to display options listed:

- **For Text Messages** the following options may appear in the display. Options are dependent on the type of message:

- **Call:** Call the phone the message was sent to.
- **Forward:** Forwards the message to another recipient.
- **Erase:** Erase the message from your Sent folder.
- **Lock/Unlock:** Locks or unlocks the entry to prevent accidental deletion.
- **Save Quick Text:** Saves the text sent in the message to the Quick Text list.
- **Add To Contacts:** Save the number of the sender to your Contacts as a new entry or add to an existing entry.
- **Erase Sent:** Erase all messages in your Sent folder.
- **Messaging Font Size:** Allows you to set the message font size for message received. Options are: Normal, Small, and Large.
- **Message Info:** Provides the following information: Send To Number (also provides the date and time the message was sent), Priority,

Message Type, Size, Attachment(s) (if a Graphic, Sound or Name Card were included in the message), Status, and Error Code.

- **For Picture Messages** the following options may appear in the display:
 - **Send:** Opens the picture message display to send the picture message.
 - **Call:** Call the phone the message was sent to.
 - **Play Again:** Replays the sound in the message.
 - **Forward:** Forwards the message to another recipient.
 - **Erase:** Deletes the message. Only displays in menu when a sound byte isn't attached to the message that was sent.
 - **Lock/Unlock:** Locks or unlocks the entry to prevent accidental deletion.
 - **Save Quick Text:** Saves the text sent in the message to the Quick Text list.
 - **Add To Contacts:** Adds the sender's information to your contact list.
 - **Erase Sent:** Allows you to erase all messages if desired.
 - **Message Info:** Provides the following information: Send To Number (also provides the date and time the message was sent), Priority, Message Type, Size, Attachment(s) (if a Graphic, Sound or Name Card were included in the message), Status, and Error Code.
- **For Video Messages** the following options may appear in the display:
 - **Call:** Call the phone the message was sent to.
 - **Play:** Replays the video.
 - **Forward:** Forwards the message to another recipient.

- **Erase**: Allows you to delete the message.
- **Lock/Unlock**: Locks or unlocks the entry to prevent accidental deletion.
- **Save Quick Text**: Saves the text sent in the message to the Quick Text list.
- **Add To Contacts**: Adds the sender's information to your contact list.
- **Erase Sent**: Allows you to erase all messages if desired.
- **Message Info**: Provides the following information: Send To Number (also provides the date and time the message was sent), Priority, Message Type, Size, Attachment(s) (if a Graphic, Sound or Name Card were included in the message), Status, and Error Code.



Note: If no sound byte is attached to the message, touch **Erase** to delete the message. Touch **Mute/Unmute/Play** to play or mute/unmute the sound byte attached to the picture message.

6. Touch the desired option.
7. Touch **Options**, and touch **Erase** to delete the message from the **Sent** folder. Touch **Yes** to delete, or **No** to return to the Sent menu.













Drafts

Draft messages are those that have been composed but never sent. You can return to the Drafts folder at any time to view, edit, or send a draft message.

Create a Draft Text or Multimedia Message

1. From the Home screen, touch  **MENU**.
2. Touch  **Messaging**.
3. Touch **1. New Message**.
4. Touch the type of message you want to create.
5. In the **To** field, touch the “**Touch Here**” text and enter the phone number of the recipient using the touchpad or the QWERTY keyboard, then touch **DONE**.
6. In the **Text** field, touch the “**Touch Here**” text and compose your message using the touch keypad or QWERTY keyboard, then touch **DONE**.
7. Touch all remaining fields to enter additional information and touch **DONE**.
8. Touch **Options**. Touch **1. Save As Draft**. A confirmation message appears in the display and your message is saved to the Drafts folder.

View and Edit Draft Messages

1. From the Home screen, touch  **MENU**.
2. Touch  **Messaging**.
3. Touch **4. Drafts**.
4. Touch the draft message that you want to view and edit.
5. Touch . The message opens. Touch the phone number field, if desired, to edit.
6. Touch  to delete numbers and use the touch keypad or QWERTY keyboard to enter numbers. Touch  when finished.
7. Touch the **Text** field. Touch  to backspace and delete any characters in the display, if desired. Touch and hold  to erase all characters in the field.
If the cursor is in front of the message, use the QWERTY keyboard and press  key. The  icon appears in the upper right of the screen. Press the right arrow key  to place the cursor at the end of the message. You can now touch  to remove any characters in the message. Touch touch  after editing the message.



8. Touch . A pop-up menu appears in the display with the options listed.

For Text Messages the following options may appear in the display:

- **Save As Draft:** Save the message to your Draft folder.
- **Priority Level:** Save the message with a High or Normal priority.
- **Callback #:** Provides the ability to send a callback # with the message.
- **Enh. Delivery Ack:** Displays a pop-up screen notifying the message sent has been received.
- **Cancel Message:** Cancels the message and allows you to save it in the Drafts folder.

For Picture-Video Messages the following options may appear in the display:



- **Preview:** Allows you to preview the message.
- **Save As Draft:** Save the message to your Draft folder.
- **Priority Level:** Save the message with a High or Normal priority.
- **Remove Picture:** Removes the picture from the message.
- **Remove Sound:** Removes the sound from the message.
- **Remove Name Card:** Removes the name card from the message.
- **Cancel Message:** Cancels the message and allows you to save it in the Drafts folder.

9. Touch the desired option to perform the function.
10. Touch the following fields and touch :
 - **Picture:** Opens the My Pictures for you to insert a picture.
 - Take Picture
 - Get New Pictures
 - **Sound:** Opens the My Sounds folder for you to insert a sound or record a new sound.
 - **Name Card:** Allows you to add your Name Card to the message.
11. Once all fields are completed, you can touch  to send the message, if desired.

Erase Options

You can erase unlocked messages in your Inbox, Drafts folder, or Sent folder. Locked messages cannot be erased.

To erase messages:

1. From the Home screen, touch  **MENU**.
2. Touch  **Messaging**.
3. Touch .
4. The following options are available:
 - **Erase Inbox:** Erases unlocked messages in your Inbox.
 - **Erase Sent:** Erases unlocked messages in your Sent folder.

- **Erase Drafts:** Erases unlocked messages in your Drafts folder.
- **Erase All:** Erases unlocked messages in all message folders (Inbox, Drafts and Sent).

Changing Message Settings

This menu allows you to define settings for messages sent or received on your Glyde™. To access your message settings, use the following steps:

1. From the Home screen, touch  **MENU**.
2. Touch  **Messaging**. Touch .
3. Choose from the following options for all message types:
 - **Entry Mode:** Sets the default entry mode for messaging. Choose from Word, Abc, ABC, or 123.
 - **Auto Save Sent:** Saves all messages sent. Choose from: On, Off, or Prompt.
 - **Auto Erase Inbox:** Erases the oldest message of the same type (Text or Picture-Video) when the maximum number of received messages of that type is exceeded in the Inbox. For example, when the Inbox exceeds 100 text messages, the first message in the list is replaced with the next incoming message. Picture messages are replaced when a maximum of 500 is reached. Choose from On or Off.
 - **Messaging Font Size:** Allows you to set the message font size for message received. Options are: Normal, Small, and Large.

- **TXT Auto View:** Automatically displays the text message when received. Choose from On or Off.
- **Pic-Video Auto Receive:** Automatically receives picture and video messages into your inbox. Choose from On or Off.
- **Quick Text:** Displays the Quick Text pre-defined entries for Text Message and Picture-Video Message. Touch  to create a New Quick Text. Touch a Quick Text message and touch  and **1. Erase** to delete a Quick Text message.
- **Voice Mail #:** Enter the speed dial entry set for your voicemail.
- **Callback #:** Allows you to use or edit the number assigned to your handset. Choose from On or Off.
- **Signature:** Adds the signature text to each message sent. Choose from None or Custom.

Voicemail

New voicemail alerts are sent via a free text message. These messages indicate how many new and urgent voicemails are in your voice mailbox. Open the free text message to view the number of new and urgent voice messages in your voice mailbox. If a caller leaves a callback number, this number will also be sent via text message.



Note: Standard Text Messaging charges do not apply.

Receive Voicemail Messages

When you receive a new voicemail message you'll hear a sound and an text message appears in the display.

- ▶ Touch to select **Listen Now** or **Listen Later**.

View Voicemail Messages in the Inbox Folder

1. From the Home screen, touch  **MENU**.
2. Touch  **Messaging**.
3. Touch **5. Voicemail**.
4. Touch  to dial voicemail and retrieve your message(s).



Mobile IM

The Instant Messaging function allows you to send and receive instant messages using one of the following communities:

- AOL[®] Instant Messenger™
- Windows Live Messenger
- Yahoo![®] Messenger

Note: You must first create the Instant Message account before accessing it on your Glyde™.

Using Mobile IM

1. From the Home screen, touch  MENU.
2. Touch  Messaging.
3. Touch **6. Mobile IM**.
4. Select your instant message community by touching the name.
5. Use the on-screen application specific functions and options to use the instant message applications.

Section 8: Changing Your Settings

This section explains the sound and phone settings for your Samsung Glyde™. It includes display settings, security settings, and extra settings associated with your Glyde™.

Note: All instructions on accessing or changing the features will begin from the **SETTINGS AND TOOLS** menu.

My Account

The My Account menu connects to the Verizon Wireless Mobile Web. You can setup Favorites or choose from the available applications.

Tools

The Tools menu provides the ability to access the following menus:

- Voice Commands: For more information, refer to *“Voice Commands”* on page 34.
- Calculator: For more information, refer to *“Calculator”* on page 107.
- Calendar: For more information, refer to *“Calendar”* on page 109.
- Alarm Clock: For more information, refer to *“Alarm Clock”* on page 110.
- Stop Watch: For more information, refer to *“Stop Watch”* on page 112.

- World Clock: For more information, refer to *“World Clock”* on page 112.
- Notepad: For more information, refer to *“Notepad”* on page 112.

Bluetooth Menu

About Bluetooth

Bluetooth is a short-range wireless communications technology capable of exchanging information over a distance of about 30 feet without requiring a physical connection.

Unlike infrared, you don't need to line up the devices to beam information with Bluetooth. If the devices are within a range of one another, you can exchange information between them, even if they are located in different rooms.

Note: When connected to your Bluetooth headset, touch the multi-function key on the headset to use Voice Commands's Voice Dial feature.

Bluetooth Service Profiles

The Bluetooth specification is a protocol that describes how the short-range wireless technology works, where individual profiles describe the services supported by individual devices. Profiles reduce the chance that different devices will not work together.

Your Glyde™ supports the following Bluetooth profile services:

- Voice Calls are supported using the following, depending on the accessory:
 - **HSP** - Headset
 - **HFP** - Hands-free profiles*
- Transfer Object allows sending an **OPP** - Object Push Profile which allows transfer of vCard (i.e., Contact information) between devices.
- Bluetooth Stereo uses **A2DP** - Advanced Audio Distribution Profile and **AVRCP** - Audio/Video Remote Control Profile.
- Printing is supported using **BIP** - **Basic Imaging** or **BPP** - Basic Printing Profiles.
- Automobile Kits can use any of the following: **HFP** - Hands-free or **PBAP** - Phone Book Access Profiles*.
- Connectivity Connections (i.e. computer) are supported using **SPP** - Serial Port (connecting two BT devices) or **DUN** - Dial Up Networking (to access the internet).





* For vehicle/accessory compatibility, go to www.verizonwireless.com/bluetoothchart. Phone does not support all Bluetooth OBEX profiles.

The following Bluetooth options are available:

Turning Bluetooth On or Off

When the Bluetooth radio is turned on, you can use the Bluetooth features available. When the Bluetooth radio is turned off, you cannot send or receive information via Bluetooth. To save battery



life or in situations where radio use is prohibited, such as airline traveling, you can turn off the Bluetooth wireless technology.

1. From the Home screen, touch  **MENU**.
2. Touch  **Settings & Tools**.
3. Touch **3. Bluetooth Menu**.
4. Touch  .



Note: If Bluetooth is turned on, the  Bluetooth icon displays in the top line of the display.

Search

This option searches for a recognized Bluetooth wireless technology device.



1. From the Home screen, touch  **MENU**.
2. Touch  **Settings & Tools**.
3. Touch **3. Bluetooth Menu**.
4. Touch **Add New Device**.

Note: If you have NOT already activated Bluetooth on your Glyde™, the message: “**TURN BLUETOOTH POWER ON?**” displays. Touch **Yes** to activate or **No** to exit.

5. The prompt: "Place Device You Are Connecting To In Discoverable Mode." is shown. Activate your Bluetooth device and touch .
6. A list of found Bluetooth devices will be displayed. Touch a Bluetooth device to be paired and touch .
7. The phone automatically attempts to send a passkey of "0000" to a hands-free device and shows the message "ATTEMPTING TO AUTO PAIR". If the default passkey is not successful, the phone will display the message "AUTO PAIR FAILED. ENTER PASSKEY". (If you are attempting to pair with a car kit, be sure to clear any error message on the car kit display first.) Enter the correct passkey for the device you want to pair using the touch keypad or QWERTY keyboard. Enter the passkey on the other Bluetooth device, if necessary.
8. Select **Yes** to pair the devices. Once connected, the Bluetooth Connected icon  appears in the upper half of the display.

Bluetooth Settings

The Bluetooth wireless technology settings menu provides the ability to view and change the device name, show the visibility, and set the security for the device.

1. From the Home screen, touch  **MENU**.
2. Touch  **Settings & Tools**.
3. Touch **3. Bluetooth Menu**.
4. Touch  **Options**. The Bluetooth menu displays with the following options:

- **My Phone Name:** Allows you enter a customized name.
- **Discovery Mode:** Allows other users to see your accessibility. Select **On** for other devices to see your device, or **Off** for no visibility.



Note: After selecting **On**, users have one minute to see your accessibility, after which Discovery Mode will automatically default back to **Off**.

- **Supported Profiles:** Displays a list of supported Bluetooth profiles. Touch a profile to view a description.
 - **My Phone Info:** Shows the handset information.
5. Touch to make your selection.



Sound Settings

The Sound Settings menu provides the ability to access the following menus:

Call Sounds

1. From the Home screen, touch  **MENU**.
2. Touch  **Settings & Tools**.
3. Touch **4. Sound Settings**.
4. Touch **1. Call Sounds**.
5. Touch **1. Call Ringtone** to get new ringtones from “Get It Now” (**Shop Ringtones**) or choose from pre-loaded ringtones.
6. Touch **2. Call Vibrate**. Touch either **On** or **Off**.

Alert Sounds

1. From the Home screen, touch  **MENU**.
2. Touch  **Settings & Tools**.
3. Touch **4. Sound Settings**.
4. Touch **2. Alert Sounds**. For the following options, you can set the tone for the message alerts.
 - **TXT Message**: Allows you to set a notification for TXT message.

- **Picture-Video Msg**: Allows you to set a notification for Picture-Video message.
- **Voicemail**: Allows you to set a notification for Voicemail Message.
- **Device Connect**: Allows you to set a notification when you connect to a device.
- **Emergency Tone**: Allows you to set the alert for emergency dialing. The options for emergency tone are:
 - **Alert**: Phone plays the Emergency Dialing tone except when the master volume setting is Vibrate or All Sounds Off.

Note: If Emergency Tone is set to **Alert** and Master Volume is set to **Vibrate**, the handset will vibrate after emergency dialing. If Emergency Tone is set to **Alert** and the master Volume is set to **All Sounds Off**, the handset will not sound after emergency dialing.

– **Vibrate**: phone will vibrate only and will not play the Emergency Dialing tone.

Note: If Emergency Tone is set to **Vibrate** and Master Volume is set to **All Sounds Off**, the handset will not sound after emergency dialing.

– **Off**: phone will not play the Emergency Dialing tone or vibrate.

5. Touch to make your selection.







Keypad Sounds

Select the sound of the touch keypad when touched.



1. From the Home screen, touch  **MENU**.

2. Touch  **Settings & Tools**.
3. Touch **4. Sound Settings**.
4. Touch **3. Keypad Sounds**.
5. Touch **Default** or **Spectrum**.

Keypad Volume



1. From the Home screen, touch  **MENU**. Touch  **Settings & Tools**.
2. Touch **4. Sound Settings**.
3. Touch **4. Keypad Volume**.
4. Touch the  **Up** or  **Down** volume icons or the  **Volume key** on the right side of the phone, to adjust the touch keypad volume.
5. Press  **SET** after selecting the desired volume level.

Service Alerts

1. From the Home screen, touch  **MENU**.
2. Touch  **Settings & Tools**.
3. Touch **4. Sound Settings**.

4. Touch **5. Service Alerts**. For the following options, you can turn the Service Alert **On** or **Off**:
 - **ERI**: Sounds an alert when you go into and out of your coverage areas.
 - **Minute Beep**: While on a call your phone beeps after every minute of usage.
 - **Call Connect**: Sounds an alert when a call is connected and when a call has ended.
 - **Service Change**: Sounds an alert when there is a change in service availability.
5. Touch to enter a desired option.



Power On/Off

1. From the Home screen, touch  **MENU**.
2. Touch  **Settings & Tools**.
3. Touch **4. Sound Settings**.
4. Touch **6. Power On/Off**. You can set the sounds for Power On and Power Off to either **On** or **Off**.



Touch Settings

Touch Settings let you set options for: Auto Lock, Vibrate Level and Sensitivity Level.



Auto Lock

1. From the Home screen, touch  MENU.
2. Touch  Settings & Tools.
3. Touch **5. Touch Settings**.
4. Touch **1. Auto Lock**. Touch **On** or **Off**.

Vibrate Level

1. From the Home screen, touch  MENU.
2. Touch  Settings & Tools.
3. Touch **5. Touch Settings**.
4. Touch **2. Vibrate Level**. To set the vibration level, touch **Off**, **Low**, **Medium** or **High**.

Sensitivity Level

1. From the Home screen, touch  MENU.
2. Touch  Settings & Tools.
3. Touch **5. Touch Settings**.



4. Touch **3. Sensitivity Level**. To set the sensitivity level for touch screen, touch **Low**, **Medium Low**, **Medium** or **Medium High**, or **High**.

Note: Default setting for Sensitivity Level is Medium. If the touch screen does not respond to your touch, try the next higher setting. Repeat if necessary until the touch screen responds to your touch.

Warning! Do not use excessive force when using the touch screen.

Display Settings

The **Display** menu affects the menu style, home screen animation, backlight settings, and more.

1. From the Home screen, touch  MENU.
2. Touch  Settings & Tools.
3. Touch **6. Display Settings**.
 - **Banner:** Create your own personalized greeting that appear in home screen, or choose the ERI Banner which displays the network in which you have subscribed.
 - **Backlight:** Choose settings for the LCD and/or Keypad (QWERTY keyboard).
 - **Wallpaper:** Choose Pictures from My Pictures, or Videos from My Videos, or special "living" (animated) wallpaper to use as the



background display for your Home screen. Choose Pictures from My Pictures to use as the background display for your Front Screen.

- **Dial Font Size:** Choose Normal or Large for the dial font size.
 - **Clock Format:** Choose digital or analog format for time display.
4. Touch to make your selection.

Banner

Banner allows you to create your own personalized greeting that appears in Home screen, or you can display the network to which you are subscribed.



To create a personal banner:

1. From the Home screen, touch  **MENU**.
2. Touch  **Settings & Tools**.
3. Touch **6. Display Settings**.
4. Touch **1. Banner**.
5. Touch **1. Personal Banner** to create a customized banner for your handset.

Note: Touch and hold  to erase an existing banner, if necessary.

6. Enter a word or short phrase (18 characters or less) to appear in the home screen using the touch keypad or the QWERTY keyboard.
7. Touch .



To turn on an ERI banner:

1. From the Home screen, touch  **MENU**.
2. Touch  **Settings & Tools**.
3. Touch **6. Display Settings**.
4. Touch **1. Banner**.
5. Touch **2. ERI Banner**. Select **On** or **Off**.

Backlight



Set the backlight for the display or touch keypad to remain on for a specified period of time.

Note: Prolonged backlight use drains your battery faster.

1. From the Home screen, touch  **MENU**.
2. Touch  **Settings & Tools**.
3. Touch **6. Display Settings**.

- Touch **2. Backlight**. The menus listed appear in the display.
 - **Display:** The following options are for the Main LCD:
 - **Duration:** Can be set to 7 seconds, 15 seconds, 30 seconds, Always On or Always Off.
 - **Brightness:** Touch the ◀ left or ▶ right icon to adjust the brightness. After selecting the brightness level, touch **DONE**.
 - **Keypad:** The following options are for the QWERTY keyboard.
 - **7 Seconds:** The keypad is on for 7 seconds.
 - **15 Seconds:** The keypad is on for 15 seconds.
 - **30 Seconds:** The keypad is on for 30 seconds.
 - **Always On:** The keypad is always on.
 - **Always Off:** The keypad is always off.
- Touch to make your selection.

Wallpaper

- From the Home screen, touch  **MENU**.
- Touch  **Settings & Tools**.
- Touch **6. Display Settings**.
- Touch **3. Wallpaper**.
- Touch **1. My Pictures** or **2. My Videos**.

- Select the desired picture, slideshow or video and touch . The selected wallpaper is applied to the Home screen.

Living Wallpaper

Your Gylde™ comes with two types of special "living" (animated) wallpaper to use as the background display for your Home screen. The **Living_Star** and **Living_Cube** wallpaper can be manipulated with the touch screen.

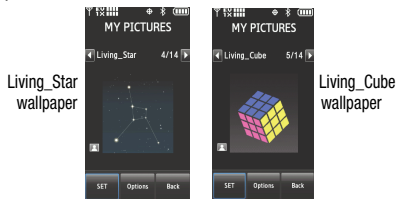

- **Living_Star:** Touch any star linked to the constellation lines and drag to create a special constellation outline of your choice. Avoid dragging a star near the My Shortcuts icon .
- **Living_Cube:** Touch and drag to spin any section of the cube to arrange and match colors.



The **Living_Star** and **Living_Cube** wallpaper are stored in **My Pictures**, under **Wallpaper**. For more information, refer to "Wallpaper" on page 79.

Dial Font Size

1. From the Home screen, touch  **MENU**.
2. Touch  **Settings & Tools**.
3. Touch **6. Display Settings**.
4. Touch **4. Dial Font Size**.
5. Touch **Normal** or **Large** font size.

Clock Format

This menu allows you to have time displayed in digital or analog format.

1. From the Home screen, touch  **MENU**.
2. Touch  **Settings & Tools**.
3. Touch **6. Display Settings**.
4. Touch **5. Clock Format**.

The following options appear in the display.



- **Digital:** Time appears in 12-hour digital format. Example: 8:00pm.
- **Analog:** Time appears in clock format. Digital format is still present in the display.
- **Off:** No time is displayed.

5. Touch the  left or  right arrow icons to make your selection and then touch  to save the option.

Phone Settings



Standalone Mode

With **Standalone Mode** on, all RF functions for your Glyde™ are disabled, and you cannot use your Glyde™ to place or receive calls.

1. From the Home screen, touch  **MENU**.
2. Touch  **Settings & Tools**.
3. Scroll the screen up and touch **7. Phone Settings**.
4. Touch **1. Standalone Mode**. Select **On** or **Off**.

Set My Shortcuts

Set My Shortcuts allows you to personalize the menu settings.



1. From the Home screen touch  **My Shortcuts** in the center of the screen to launch **My Shortcuts** menu.
2. Touch . The prompt; “**TAP TO REPLACE**” displays. Touch any of the shortcut icons you want to replace.

Note: While in the “**TAP TO REPLACE**” field, you can touch  to reset all shortcuts to the default setting, if desired.

3. The prompt; “**REPLACE SHORTCUT - Replace <name of selected shortcut> with:**” displays.
4. Touch any of the shortcut options to make your selection.



For more information about replacing shortcuts; see “*Modifying My Shortcuts*” on page 22.

Voice Commands

1. From the Home screen, touch  **MENU**.
2. Touch  **Settings & Tools**.
3. Scroll the screen up and touch **7. Phone Settings**.
4. Touch **3. Voice Commands**. The following options appear:
 - **Digit Dial Readout:** Select On or Off.
 - **TXT Msg Readout:** Select On or Off.
 - **Choice List:** Select: Automatic or Always Off.
 - **Sensitivity:** Select one of the following options for speech recognition sensitivity: Reject More, Automatic and Reject Less.
 - **Train Voice:** Select: Adapt Voice, Reset Voice or Tutorial.
 - **Prompts:** The following options appear:
 - **Mode:** Select: Prompts, Readout or Tones Only.
 - **Audio Playback:** Select: Speakerphone or Earpiece.
 - **Timeout:** Select: 5 seconds or 10 seconds.
 - **Call Alert:** Select: Ring Only, Caller ID + Ring or Name Repeat.

Language



Change the display language from English to Spanish or vice versa.

1. From the Home screen, touch  **MENU**.
2. Touch  **Settings & Tools**.
3. Scroll the screen up and touch **7. Phone Settings**.
4. Touch **4. Language**.
5. Touch the desired language to make your selection.

Location

Note: This feature is only available on the Verizon Wireless network.

The Location Global Positioning Service (GPS) setting identifies your location to the network. You can fully enable this setting or set GPS to work only in the case that you dial 911 from your Glyde™.

1. From the Home screen, touch  **MENU**.
2. Touch  **Settings & Tools**.
3. Scroll the screen up and touch **7. Phone Settings**.
4. Touch **5. Location**. The following options appear in the display:

- **Location On:** GPS location setting is on wherever the feature is available.
 - **E911 Only:** GPS location setting is on whenever you dial 911 only.
5. Touch to make your selection.

Security

The **Security** menu allows you to lock your Glyde™, set restrictions, and other security options.



1. From the Home screen, touch  **MENU**.
2. Touch  **Settings & Tools**.
3. Scroll the screen up and touch **7. Phone Settings**.
4. Touch **6. Security**.
5. Enter the lock code (factory settings are the last four digits of your telephone number) using the touch keypad or the QWERTY keyboard and touch . The following options appear in the display:
 - **Edit Codes:** Allows you to change the Lock Code for Phone Only Lock or Calls & Services.
 - **Restrictions:** Allows you to restrict the Location Setting (Lock/Unlock Setting), Calls (Outgoing or Incoming calls), messages (Outgoing or Incoming messages) and dial-up modems (Allow or Block).

- **Phone Lock Setting:** Allows you to set the phone to Unlocked or lock the phone On Power Up.
- **Lock Phone Now:** Allows you to lock the handset.
- **Restore Phone:** All settings are reset to factory default settings and all user data is erased including pictures, videos, music, messages, contacts, and downloaded applications stored on the phone.

Edit Codes



The default lock code is the last four digits of your phone number. **Edit Code** allows you to change to a lock code of your preference.

1. From the Home screen, touch  **MENU**.
2. Touch  **Settings & Tools**.
3. Scroll the screen up and touch **7. Phone Settings**.
4. Touch **6. Security**. You're prompted to enter the lock code. The default lock code is the last four digits of your telephone number.
5. Enter the **Lock Code** and touch . Several security options appear in the display.
6. Touch **1. Edit Codes**. The following options display:
 - **Phone Only:** Allows you to edit the lock code for only the handset.
 - **Calls & Services:** Allows you to edit the lock code for all Calls & Services. Touch an option.

7. At the “**ENTER NEW CODE**” prompt, enter the new lock code and touch .
 8. You're prompted to confirm the new lock code.
 9. At the “**RE-ENTER NEW CODE**” prompt, re-enter lock code and touch .
- “**PHONE ONLY CODE SET**” or “**CALLS & SERVICES CODE SET**” message appears in the display confirming that your lock code was changed.

Note: Your Glyde™ does not allow you to view the lock code for security reasons. If you change the lock code, record the new code.



Restrictions

1. From the Home screen, touch  **MENU**.
2. Touch  **Settings & Tools**.
3. Scroll the screen up and touch **7. Phone Settings**.
4. Touch **6. Security**. You're prompted to enter the lock code. The default lock code is the last four digits of your telephone number.
5. Enter the **Lock Code** and touch . Several security menus appear in the display.

6. Touch **2. Restrictions**.
 7. Enter the **Calls and Services Code** then touch . The default calls and services code is the last four digits of your telephone number.
- The following options display:
- **Location Setting:** Options are Lock Setting and Unlock Setting.
 - **Calls:** Options are Incoming Calls and Outgoing Calls.
 - **Messages:** Options are Incoming Messages and Outgoing Messages.
 - **Dial-Up Modem:** Options are Allow All and Block All.
8. Touch to make your selection.



Phone Lock Setting

Phone Lock Setting restricts the use of your Glyde™ with the exception of outgoing calls to 911. Phone Lock Setting allows you to answer calls, but to place calls (except to emergency numbers) you have to unlock the Glyde™.



1. From the Home screen, touch  **MENU**.
2. Touch  **Settings & Tools**.
3. Scroll the screen up and touch **7. Phone Settings**.

4. Touch **6. Security**. You're prompted to enter the lock code. The default lock code is the last four digits of your telephone number.
5. Enter the **Lock Code** and touch . The security menu appears in the display.
6. Touch **3. Phone Lock Setting**. The following options display:
 - **Unlocked**: If locked, unlocks the device or phone, depending on your selection.
 - **On Power Up**: The Lock Code is required whenever you power up the phone.
7. Touch to make your selection.

Lock Phone Now

1. From the Home screen, touch  **MENU**.
2. Touch  **Settings & Tools**.
3. Scroll the screen up and touch **7. Phone Settings**.
4. Touch **6. Security**. You're prompted to enter the lock code. The default lock code is the last four digits of your telephone number. Touch **OK** to proceed.
5. Enter the **Lock Code** and touch . The security menu appears in the display.

6. Touch **4. Lock Phone Now**.

Your phone returns to the Home screen. To unlock, touch the  **Unlock** icon at the top of the Home screen and enter the security code at the prompt and touch .

Restoring Your Phone Memory to Factory Condition

Restore Phone returns all setup options to their factory default.

1. From the Home screen, touch  **MENU**.
2. Touch  **Settings & Tools**.
3. Scroll the screen up and touch **7. Phone Settings**.
4. Touch **6. Security**. You're prompted to enter the lock code. The default lock code is the last four digits of your telephone number.
5. Enter the **Lock Code** and touch . The security menu appears in the display.
6. Touch **5. Restore Phone**. A prompt appears in the display asking if you wish to restore default settings and erase all user data including pictures, videos, music, messages, contacts, and downloaded applications stored on the phone.



7. Touch **Yes** to reset and restore default settings, or touch **No** to return to the Security list.

Warning: Choosing the **Restore Phone** option will return your Glyde™ to the default settings and erase all user data including pictures, videos, music, messages, contacts and downloaded applications stored on the phone.

Note: After your Glyde™ power cycles back on, you must enter *228 and press  to re-program your phone number.



System Select

The **System Select** menu allows you to set your roaming options. For more information, refer to “*Roaming Options*” on page 33.

1. From the Home screen, touch  **MENU**.
2. Touch  **Settings & Tools**.
3. Scroll the screen up and touch **7. Phone Settings**.
4. Scroll the screen up and touch **7. System Select**. The following options appear:
 - **Home Only**
 - **Automatic**
5. Touch to make your selection.

NAM Select

Your Glyde™ provides the option of selecting between two NAMs (Number Assignment Modules) or phone numbers. Select either NAM1 or NAM2.



1. From the Home screen, touch  **MENU**.
2. Touch  **Settings & Tools**.
3. Scroll the screen up and touch **7. Phone Settings**.
4. Scroll the screen up and touch **8. NAM Select**. The following options appear in the display: **NAM1** and **NAM2**.
5. Touch to make your selection.





Call Settings

The **Call Settings** menu allows you to select the method for answering incoming calls, setting redial options, setting data options, voice privacy, and more.

Answer Options



The Answer Options menu allows you to select the method for answering incoming calls.

1. From the Home screen, touch  **MENU**.
2. Touch  **Settings & Tools**.
3. Scroll the screen up and touch **8. Call Settings**.

4. Touch **1. Answer Options**. The following options appear in the display:
 - **Slide Open**: Calls are answered when you open the slide, or when you touch the  button.
 - **Any Key**: Calls are answered when you touch the  button, or when you press any key on the QWERTY keyboard with the slide open.
 - **Auto w/ Handsfree**: Calls are answered automatically with a 5 second delay.
5. Touch the method you wish to use for answering calls, then touch , or touch . Touch **Mark All** to select all options.
6. Touch .

Auto Retry

Auto Retry automatically redials voice/data calls after a preset period of time.

1. From the Home screen, touch  **MENU**.
2. Touch  **Settings & Tools**.
3. Scroll the screen up and touch **8. Call Settings**.
4. Touch **2. Auto Retry**. The following options appear in the display:

- On
- Off



5. Touch to make your selection.

TTY Mode

Before you can use your Glyde™ with a TTY device, you'll need to enable TTY functions in your Glyde™. For more information, refer to “TTY” on page 33.

One Touch Dial



This option to enables or disables the speed dialing feature.

1. From the Home screen, touch  **MENU**.
2. Touch  **Settings & Tools**.
3. Scroll the screen up and touch **8. Call Settings**.
4. Touch **4. One Touch Dial**. Touch to select **On** or **Off**.

For more information, refer to “Speed Dialing” on page 47.

Call Screen Layout

Use this option to turn the touch keypad on or off.



1. From the Home screen, touch  **MENU**.
2. Touch  **Settings & Tools**.

3. Scroll the screen up and touch **8. Call Settings**.
4. Touch **5. Call Screen Layout**. Touch to select **Dial Pad On** or **Dial Pad Off**.



Voice Privacy

Note: This feature is only available on the Verizon Wireless network.

Voice Privacy when enabled turns on advanced voice encryption. Voice privacy can be set to **On** or **Off**.

1. From the Home screen, touch  **MENU**.
2. Touch  **Settings & Tools**.
3. Scroll the screen up and touch **8. Call Settings**.
4. Touch **6. Voice Privacy**. The following options appear in the display: **On** and **Off**
5. Touch to select an option.



Data Settings

1. From the Home screen, touch  **MENU**.
2. Touch  **Settings & Tools**.
3. Scroll the screen up and touch **8. Call Settings**.

4. Scroll the screen up and touch **7. Data Settings**. The following options appear:
 - **Data Off:** Phone operates in normal voice call mode.
 - **Data For Next Call:** Data call is enabled for next call only. Phone will reset to Data Off mode after call.
 - **Until Power Off:** Phone will remain in Data Mode until phone is powered off.
5. Touch to select an option.



DTMF Tones

Use this menu to set DTMF settings to **Normal**, or **Long**.

1. From the Home screen, touch  **MENU**.
2. Touch  **Settings & Tools**.
3. Scroll the screen up and touch **8. Call Settings**.
4. Scroll the screen up and touch **8. DTMF Tones**. The following options appear:
 - **Normal:** Select for a normal tone.
 - **Long:** Select for an extended tone.
5. Touch to select an option.

Memory

The Memory menu allows you to manage your **Save Options** (for Pictures, Videos, and Sounds) on your **Phone Memory** or **Card Memory**. You can also set the memory usage for pictures, videos, music, sounds, and ringtones on your Glyde™ and microSD™ card.

1. From the Home screen, touch  **MENU**.
2. Touch  **Settings & Tools**.
3. Scroll the screen up and touch **9. Memory**. The following options are available:
 - **Save Options:** You can set your Pictures, Videos, and Sounds to be saved to either phone memory or card memory.
 - **Phone Memory:** Allows you to see the memory usage for everything stored on your phone. The following options are available:
 - **Phone Memory Usage:** Displays the current memory usage and allocation figures for the various applications and folders stored on the phone. These include: Available, Used, Total, My Pictures, My Videos, My Ringtones, My Music, My Sounds, Applications, Pic/Video Msg, and SMS/EMS/WAP.
 - **My Pictures:** Pictures you have saved from a Picture message, downloaded via the “Get It Now” application, or taken using your phone.
 - **My Videos:** Video Clips you have saved from a Video message, downloaded via the “Get It Now” application, or taken using your phone.



- **My Ringtones:** Ringtones you have downloaded via the “Get It Now” application.
- **My Music:** Music you have downloaded directly from the V CAST Music catalog or music you have transferred from your PC using Sync Music.
- **My Sounds:** Sounds you have downloaded, recorded using your phone, or saved from a Picture message with Sound attached.

Note: Your Glyde™ does not come with a microSD™ memory card. A card must be purchased as an accessory. See your service provider for more information.

- **Card Memory:** Allows you to see memory usage of everything stored on your microSD™ card. The following file options are available for the removable microSD™ memory card:
 - **Card Memory Usage:** Displays the current memory usage and allocation figures for the various applications and folders stored on the card. These include: Available, Used, Total, My Pictures, My Videos, My Music, and My Sounds.
 - **My Pictures:** Pictures you have saved from a Picture message or taken using your phone.
 - **My Videos:** Video Clips you have saved from a Video message or taken using your phone.
 - **My Music:** Music you have downloaded directly from the V CAST Music catalog or music you have transferred from your PC using Sync Music.
 - **My Sounds:** Sounds you have recorded using your phone or saved from a Picture message with Sound attached.

Phone Info

The **Phone Info** menu allows you to view the software and hardware information, your assigned number, and an icon glossary for your Glyde™.

1. From the Home screen, touch  **MENU**.
2. Touch  **Settings & Tools**.
3. Scroll the screen up and touch **0. Phone Info**.
4. Touch **1. My Number** to display the Mobile Device and the Mobile Identification numbers.
5. Touch **2. SW Version** to view the version of software, PRL, ERI, Browser, Get it Now, MSUI, Hardware, and MEID on your phone.
6. Touch **3. Icon Glossary** to view the list of icons with a brief description.



Section 9: Get It Now

This section describes how to download and play music, tones, and video. It also outlines how to take, record and store images and videos, sounds, and ringtones using your Samsung Glyde™.

Note: All instructions on accessing or changing the features will begin from the **GET IT NOW** menu.

Get It Now

The Get It Now menu provides sub-menus to Music & Tones, Picture & Video, Games, Internet Browser, Browse & Download and Extras. You can also view memory info to see how much space you've used (and have left) for stored media. Use the following steps for each **Get It Now** sub-menu.

1. From the Home screen, touch  **MENU**.
2. Touch  **Get it Now** to access the various downloads and application options.

Before downloading any music, tones, pictures, videos, games, etc., check the available phone memory. See “Memory” on page 88.

Note: When you launch V CAST Music, V CAST Videos, the Internet Browser, or a downloaded application, you will see the following prompt (unless you have already selected “**Don't Show Again**”): “**PRESS LOCK KEY ON SIDE TO LOCK SCREEN**”. To not show the prompt again, press “**Don't Show Again**” or press “**OK**” to continue.

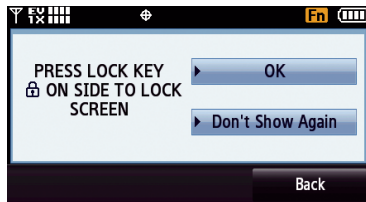

Music & Tones

This menu allows you to get new tunes and tones, record new sounds, and set tunes and tones as your ringtone. It also allows you to access your music files.

V CAST Music

You can use the V CAST Music option to download music from the V CAST Music catalog directly to phone memory or to a removable memory card.

Formatting a microSD™ Card using your PC

For best playback of songs stored to the microSD™ memory card, you should reformat your memory card with PC format FAT32.



Note: Any content currently stored on the microSD™ memory card will be lost when this procedure is performed.





1. Insert the microSD™ memory card into an SD card adapter.
2. Insert the SD card adapter into the SD card reader slot.
3. Plug the SD card reader into a USB port on your PC.
4. On your PC, go to your **My Computer** directory and highlight the drive that represents the SD card reader.
5. Right click and select the **Format** option.
6. Under the **File System** option, select **FAT32** and click the **Start** button.
7. Your microSD™ memory card will be reformatted.

Note: Your Glyde™ can support microSD™ memory cards with a capacity of 8 GB maximum.

8. Remove the microSD™ card from the SD card reader and insert it back into your phone. The **My Music** directory will automatically be created on the microSD™ memory card the first time that you access V Cast Music/My Music/Sync Music from your phone.



Downloading Music from the V CAST Music Catalog

1. From the Home screen, touch  **MENU**.
2. Touch  **Get it Now**.
3. Touch **1. Music & Tones**.
4. Touch **1. V CAST Music** to open the V CAST Music catalog in landscape mode on your Glyde™.
5. Browse or search the catalog to preview the songs.
6. Touch the music you want to purchase.
7. To preview the selected song, touch **Preview** to hear a 20 second preview of the song.
8. Touch **Buy** to purchase the song.
9. The **CONFIRM PURCHASE** screen will display the price and items you selected to purchase. Touch **Buy This Song** to accept the terms.

10. Touch  to download the song. You will have the option to download to the phone memory or memory card (recommended). After choosing a location for the song, the downloading screen will appear.
11. Touch  to play the downloaded song immediately if desired or touch  **BACK** to return to the previous screen.
12. Press the  **Home** key on the front of the phone to return to the Home screen.



Get New Ringtones

You can use this option to download new ringtones from the Internet.

1. From the Home screen, touch  **MENU**.
2. Touch  **Get it Now**.
3. Touch **1. Music & Tones**.
4. Touch **2. Shop Ringtones**.
5. Touch **1. Shop Ringtones**.
6. You are connected to the **GET IT NOW** catalog and presented with available provider ringtone applications.

7. Press the  **Home** key on the front of the phone to return to the Home screen.

My Ringtones

1. From the Home screen, touch  **MENU**.
2. Touch  **Get it Now**.
3. Touch **1. Music & Tones**.
4. Touch **3. My Ringtones**.
5. Touch **1. Shop Ringtones** to access the Get It Now catalog to download new ringtones. Or if you have already downloaded ringtones, touch your selection.
6. Press the  **Home** key on the front of the phone to return to the Home screen.



My Music

The Music Player can be used to play music files that you have downloaded from the V CAST Music catalog or that you have transferred from your PC using Sync Music.

You can play your music with the phone open or closed.

Playing Music



1. From the Home screen, touch  **MENU**.
2. Touch  **Get It Now**.
3. Touch **1. Music & Tones**.
4. Touch **4. My Music**.
5. The **MY MUSIC** screen appears in the display. The following options appear in the display:

- **Genres:** This option organizes your songs by music type. For example: Alternative, Classical, Jazz, etc. Each folder will contain all songs within that genre.
- **Artists:** This option organizes your songs by artist.
- **Albums:** This option organizes your songs by album title. Even if you only have one song from an album, a folder for the album will display.
- **Songs:** This option organizes your songs by song title. To add a song to a playlist, touch  and touch **Add to playlist** to place the song into one of your playlists.
- **Playlists:** Any playlists that you have created are displayed in this option. Enter a name for the playlist in the "Enter text" box to create a new playlist. With a playlist highlighted, touch  to Add songs, View playlist, Edit playlist or rename playlist.



Note: **Options** is only available once a playlist is created.





- **Inbox:** This repository is where alert notifications are received when new music from a selected artist is available for download.
 - **Play All:** This option will play all of your songs in list order.
 - **Shuffle:** This option will re-sort a playlist order.
6. Touch **Songs** and touch a song to play. While the song is playing, touch  **Options** to select from the following:
 - **Play All:** This option will play all of your songs in list order.
 - **Repeat:** Repeats the selected song.
 - **Shuffle:** Re-sorts the current playlist order.
 - **My Music:** Returns to My Music menu.

Note: The song playing will automatically stop playing when this is done. To resume playing of the song, touch .





7. Touch an option if desired.
8. During song playback, touch  to advance to the next song track in the current playlist, or touch  to skip to the previous song track.



Creating a Playlist

1. From the Home screen, touch  **MENU**.
2. Touch  **Get It Now**.
3. Touch **1. Music & Tones**.





4. Touch **4. My Music**.
5. Touch  **Playlists**.
6. The “**CREATE PLAYLIST**” displays. Enter a title for the playlist in the “Enter text” box using the QWERTY keyboard and touch the Enter key .
7. Touch the songs to add to the playlist or touch  **Mark All** and touch  **Done**. You are returned to the **My Music** menu screen.
8. Press the  **Home** key on the front of the phone to return to the Home screen.

Editing a Playlist

1. From the Home screen, touch  **MENU**.
2. Touch  **Get It Now**.
3. Touch **1. Music & Tones**.
4. Touch **4. My Music**.
5. Touch  **Playlists**.
6. Touch  **OPTIONS** next to the desired playlist. Touch **Edit Playlist**.

7. The options: **Remove**, **Move** or **Add** appears at the top screen.
 - Touch a song and touch Remove to remove the song from the current playlist.
 - Touch a song and touch Move to move the song up or down in the current playlist order.
 - Touch Add to add another song to the current playlist.
8. Touch  **BACK** to return to the Playlists screen or press the  **Home** key on the front of the phone to return to the Home screen.

My Sounds

1. From the Home screen, touch  **MENU**.
2. Touch  **Get It Now**.
3. Touch **1. Music & Tones**.
4. Touch **5. My Sounds**.
5. Touch **1. Record New**.
Touch  **Options** to select the recording mode of either Limit for Pic Msg or Normal.
6. Touch  **REC** to begin recording.

7. During the recording, touch **STOP** to stop and automatically save the recording to My Sounds, or touch **PAUSE** to pause and resume the recording appropriately.
8. Touch **STOP** to save the recorded sound.

Sync Music

This option allows you to transfer music files from your PC. In order to use this option, you must load the **V CAST** Music Manager, (supplied on the CD), on your PC.

Note: For PCs running Windows VISTA® operating system, you must use Music Manager to sync music to your phone.

1. Open Music Manager. Don't have music manager? Download it for free at: www.verizonwireless.com/musicmanager.
2. Plug in the USB cable to your phone and connect it to a USB port on your PC.
3. Your Glyde™ will begin connecting to your computer. After the connection is complete, the message: "Connected" will display.
4. Drag and drop the songs you want to sync from your computer into the Sync List.

5. Select **Sync Now**. The songs will begin synchronizing to your Glyde™.
6. When you are finished synchronizing your songs, touch **My Music** to display the **My Music** menu.
7. Disconnect the USB cable and close Music Manager.

Picture & Video







This menu allows you to get new Pictures and Videos via Get It Now and V CAST Video, or take new Pictures or Videos using your Glyde™'s camera/camcorder. You can also view the saved pictures and videos.

V CAST Video

V CAST, the next generation wireless technology that unveils a whole new multimedia experience at your fingertips, provides access to vibrant, full-color content from some of the biggest names in entertainment. V CAST is your link to video on demand, which allows you to view or download video clips that contain breaking news, sports highlights, weather and more.

For additional information regarding V CAST Videos and its use, see www.verizonwireless.com.

NOTE: While playing a video, you may touch the screen to view the following controls:

-  Touch to pause the video.
-  Touch to resume playing the video.
-  Touch to rewind the video.
-  Touch to fast forward the video.
-  Touch to access the following Options:
 - **Get V CAST Videos**
 - **Video Info:** to view video Title, Duration, file size and video height & width.
 - **About:** to view about video player.
 - **Help:** to view layout of player screen controls.
-  Touch to return to previous screen.



Note: To access and download videos, you must have the  icon displayed.

Browsing, Selecting and Playing Video Clips

1. From the Home screen, touch  **MENU**.
2. Touch  **Get It Now**.
3. Touch **2. Picture & Video**.
4. Touch **1. V CAST Videos**.

5. Touch the video category of your choice. You may need to touch several selection menus before seeing a screen with video titles on it.
6. On a video title screen, you may touch  to do one of the following:
 - **Home:** return to Home screen of Video Player.
 - **Save Video:** if possible.
 - **Search:** to find specific artist or video title
 - **Manage Subscription:** to add or remove premium subscription
 - **Alerts:** if possible for that title.
 - **About:** displays the version number of the V CAST video software.
 - **Video Info:** displays information about the selected video.
7. To view a video, touch the title.

Downloading a Video Clip

1. From the Home screen, touch  **MENU**.
2. Touch  **Get It Now**.
3. Touch **2. Picture & Video**.
4. Touch **1. V CAST Videos**.
5. Touch the video category of your choice.
6. Touch a video title that you want to download and save.

7. You will see a pop-up notification similar to the following:
“The first time you view this clip, you will be charged (payment amount). If you have previously viewed this clip, you will not incur any additional charges. Proceed?” Touch “Yes” or “No”.
8. If you touch “Yes” to proceed, you will see the message “Downloading - %” with the percentage of completion. If you decide to cancel the download in-progress, touch “Cancel”.
9. Once the download is completed, “Download Complete. Play video now?” appears in the display.



Note: If you see the “Download Complete. Play video now?” prompt, the video is saved in the “My Videos” folder.

10. Touch **Yes** to view the video, or select **No** to return to the **V CAST Videos** menu.



Note: Not all video content available can be downloaded to your Glyde™ however, all content is available for viewing.





Deleting Video Clips

1. From the Home screen, touch  **MENU**.

2. Touch  **Get It Now**.
3. Touch **2. Picture & Video**.
4. Touch **4. My Videos**.
5. From the thumbnail view, touch .
6. Touch **3. Manage My Videos**.
7. Touch **1. Erase**.
8. Touch the appropriate video thumbnail(s) to mark for deletion, and touch .
9. ‘ERASE VIDEO FROM MY VIDEOS AND SETTINGS?’ displays. Touch **Yes** to delete video or **No** to cancel.



Configure Alerts for New Video Clips

1. From the Home screen, touch  **MENU**.
2. Touch  **Get It Now**.
3. Touch **2. Picture & Video**.
4. Touch **1. V CAST Videos** to launch **V CAST Videos**.
5. Touch to select the **V CAST Videos** categories you want to configure an alert.
6. Choose a sub category, if applicable, then touch .
7. Touch **Alerts**.

8. Touch **Configure alerts**.
9. Open the slide, turn on  if necessary, and with the directional arrow keys scroll to highlight the appropriate alert and press  or touch  button to select it.
10. Use the directional key to scroll up and read the subscription terms, and then highlight **Save** and press  or touch  button.



Note: Fees apply for text messages/alerts both sent and received.

Get New Pictures

1. From the Home screen, touch  **MENU**.
2. Touch  **Get It Now**.
3. Touch **2. Picture & Video**.
4. Touch **2. Get New Pictures**.
5. Touch **1. Shop Pictures**. Follow the on-screen prompts to download pictures and wallpaper from the Get It Now server. Appropriate subscription charges may apply.

My Pictures

My Pictures allows you to review the pictures taken with the camera feature or downloaded and stored into your phone and/or microSD™ card.

1. From the Home screen, touch  **MENU**.
2. Touch  **Get It Now**.
3. Touch **2. Picture & Video**.
4. Touch **3. My Pictures**.

If you touch  before selecting a photo, the following options appear:

- **Take Picture:** Activates the camera.
- **Get New Pictures:** Allows you to download pictures and wallpaper from the Get It Now server.
- **Manage My Pics:** Launches the Manage My Pics submenu. Select one of the following:
 - **Erase:** Allows you to erase selected picture files.
 - **Make Slide Show:** Allows you to create a slide show with selected pictures.
 - **Move:** Allows you to move selected pictures that are not locked from the phone's internal memory to a memory card, or from a memory card to the phone's internal memory.

Note: The **Move** option is only visible when a memory card is inserted into your GLYDE™.

- **Lock:** Allows you to lock selected pictures to prevent accidental deletion.
- **Unlock:** Allows you to unlock selected pictures.

5. Touch a photo to view the picture. Touch **Options** to select from the appropriate options.

If the photo is one of the pre-loaded photos, the following options are available:

- **Send:** Launches the New Picture Message menu field.
- **Manage My Pics:** Launches the Manage My Pics submenu. Select one of the following:
 - **Erase:** Allows you to erase selected picture files.
 - **Make Slide Show:** Allows you to create a slide show with selected pictures.
 - **Move:** Allows you to move selected pictures that are not locked from the phone's internal memory to a memory card, or from a memory card to the phone's internal memory.
 - **Lock:** Allows you to lock selected pictures to prevent accidental deletion.

Note: **Move** and **Lock** is only available for allowed pictures.

– **Unlock:** Allows you to unlock selected pictures.

- **File Info:** Provides the date, time, resolution, size and rights to the selected picture.

If the photo is one that you have taken using the Camera function, or have downloaded, the following options are available:

- **Erase:** deletes the photo from your My Pictures folder.
- **Send:** sends the photo as a Picture Message, to a Online Album, or via a Bluetooth device.
- **Print:** send the photo through a USB connection or Bluetooth device to be printed.
- **Manage My Pics:** Launches the Manage My Pics submenu. Select one of the following:
 - **Erase:** Allows you to erase selected picture files.
 - **Make Slide Show:** Allows you to create a slide show with selected pictures.
 - **Move:** Allows you to move selected pictures that are not locked from the phone's internal memory to a memory card, or from a memory card to the phone's internal memory.
 - **Lock:** Allows you to lock selected pictures to prevent accidental deletion.
 - **Unlock:** Allows you to unlock selected pictures.
- **Rotate:** allows you to use special touch buttons on the display to rotate (by 90 degree increments) or to reflect the image (flip) either



horizontally or vertically. Touch  to save the positional change.

- **Create Postcard:** Allows you to merge a sketched picture with a regular picture to create a postcard.
- **Rename:** Allows you to rename the selected picture.
- **File Info:** Provides the date, time, resolution, size and rights to the selected picture.

6. Touch to make your selection.

Manage My Pics

Manage My Pics allows you to organize your pictures. You can create a slide show with selected pictures, move your pictures from the phone's internal memory to a microSD™ memory card or from the memory card to the phone's internal memory. You can also erase selected pictures or lock them to prevent accidental deletion.

1. From the Home screen, touch  **MENU**.
2. Touch  **Get It Now**.
3. Touch **2. Picture & Video**.
4. Touch **3. My Pictures**.
5. Touch .
6. Touch **3. Manage My Pics**: Select from the following options:



- **Erase:** Allows you to erase selected picture files.
- **Make Slide Show:** Allows you to create a slide show with selected pictures.
- **Move:** Allows you to move selected pictures that are not locked from the phone's internal memory to a memory card, or from a memory card to the phone's internal memory.
- **Lock:** Allows you to lock selected pictures to prevent accidental deletion.
- **Unlock:** Allows you to unlock selected pictures.

7. Touch to make your selection.

Make a Slide Show

Make Slide Show allows you create a slide show with selected pictures.

Note: To create a slideshow, you must have a minimum 4 pictures and a maximum of 18.

1. From the Home screen, touch  **MENU**.
2. Touch  **Get It Now**.
3. Touch **2. Picture & Video**.
4. Touch **3. My Pictures**.
5. To make a slide show of the pictures, touch .
6. Touch **3. Manage My Pics**.

7. Touch **2. Make Slide Show**.
8. Touch select the desired pictures (minimum of four pictures), or touch  and touch **1. Mark All**. A slide show can use up to 18 photos.

9. Touch .

The selected photos are shown in the Make Slide Show display. Touch  for the following:

- **Set as Wallpaper:** Allows you to set the video as your wallpaper.
- **Preview:** lets you see a preview of what the slide show will look like.
- **Change order:** lets you change the order of the photos in the slide show.
- **Remove:** allows you to remove photos from the slide show.
- **Settings:** allows you to set the following settings for the slide show:
 - **Effects:** lets you select: None, Random, Page, Blind_Vertical, Block_In, Circle_Up, Spray, Radio_Up, Multi_In, Jewel, Water_Out and AlphaBlock.
 - **Duration:** allows you to set how long each photo displays: 1, 2, or 3 seconds.

Touch  after choosing the desired settings.

10. Touch  to save the slide show.

11. Enter the name of the slide show where prompted, using either the touch keypad or the QWERTY keyboard, and touch .

In the **MY PICTURES** screen, a slideshow icon  will appear in the lower left corner of a thumbnail view of the picture containing the slide show. Touch the picture with the slideshow icon to view the slideshow.

My Videos

Note: See player controls at beginning of Picture & Video section.

My Videos allows you to review videos taken with the camcorder feature or downloaded and stored into your phone and/or microSD™ card. Video clips you save are stored in **My Videos**. You can access video clips without launching the **V CAST Videos** application and delete your saved video clips directly.

1. From the Home screen, touch  **MENU**.
2. Touch  **Get It Now**.
3. Touch **2. Picture & Video**.
4. Touch **4. My Videos**.

Touch **Options** before touching a video selection, and the following options display:

- **Record Video:** Activates the camcorder and allows you to record a video clip.
- **V CAST Videos:** Launches the V CAST Video service.
- **Manage My Videos:**
 - **Erase:** Allows you to erase selected video files.
 - **Move:** Allows you to move selected videos that are not locked, from the phone's internal memory to a memory card or, from a memory card to the phone's internal memory.
 - **Lock:** Allows you to lock selected videos to prevent accidental deletion.
 - **Unlock:** Allows you to unlock selected videos.

5. Touch a video to play.

For self-recorded videos, touch  **Options** with a video active for the following:

- **Erase:** Allows you to erase the selected video file.
- **My Videos:** Takes you back to the My Videos folder.
- **Send:** Allows you to send the video in a Video Message, or to an Online Album.
- **Set as Wallpaper:** Allows you to set the video as your wallpaper.
- **Manage My Videos**
 - **Erase:** Allows you to erase selected video files.

- **Move:** Allows you to move selected videos, that are not locked from the phone's internal memory to a memory card, or from a memory card to the phone's internal memory.
- **Lock:** Allows you to lock selected videos to prevent accidental deletion.
- **Unlock:** Allows you to unlock selected videos.
- **Rename:** Allows you to rename the video.
- **File Info:** Shows information about the duration, date and time video was recorded, resolution that the video was recorded at, and the size of the file.
- **Help:** Shows shortcuts on how to use the touch keys on the video player.

6. Touch to make your selection.

Take Picture



1. From the Home screen, press the **Camera/Camcorder** key  on the lower right side of the phone.

Note: If you would like to switch to the camcorder, touch and hold the Camera/Camcorder key  to launch camcorder.

2. Touch **Options** to choose the specific camera settings. Touch the navigation key up or down to advance to each setting category, and to make selections within each category. The following categories are available:
 - **Settings:** Allows you to customize your image settings.

- **Color Effects:** Allows you to set this option from the following choices: Normal, Black & White, Sketch, Antique, Negative, Green and Aqua.
- **White Balance:** Allows you to set this option from the following choices: Auto, Sunny, Cloudy, Tungsten, or Fluorescent.
- **Brightness:** Allows you to balance the brightness of the photo.
- **Memory:** Allows you to select the location for saved pictures. Save to phone or microSD™ card.
- **Auto Name:** Allows you to set Auto Name to On or Off. The file is saved and file name is selected automatically.
- **ISO:** Allows you to set the “speed” or the camera’s sensitivity to light. Options are: Auto, 100, 200 and 400.
- **Metering:** Allows you to choose a specific part of the camera’s metering area to read. Options are: Average, Center and Spot.
- **Icon Display:** Allows you to hide or view the camcorder icons in the display when recording a video. Options are: Display All, Partial, Guideline and No Icons.
- **Sound Effect:** Allows you to select the Ready Sound and/or Shutter Sound.
- **Reset Settings:** Return camcorder options to default settings.
- **Flash:** Allows you to set the flash for the camera to: Off, Auto, Only This Shot or On.
- **Auto Focus:** Allows you to turn autofocus on or off.
- **Self Timer:** Off, 3 Seconds, 5 Seconds, 10 Seconds.
- **Quality:** Allows you to set the quality of the picture. Options are: Fine, Normal and Economy.

- **Resolution:** Allows you to set the camera’s resolution for the pictures. Options are: 1600x1200, 1280x960, 1024x768, 640x480, 320x240 and 176x144.
- **Multishot:** Allows you to set the multishot mode. Options are: Series Shot or Divided Shot.
- **Camcorder:** Allows you to activate the camcorder.

3. Touch **TAKE** or press the **Camera/Camcorder** key  on the lower right side of the phone, to capture a picture. The camera’s metering icon will turn from red to green just before the picture is taken. Touch **SEND** to send the picture as a New Picture Msg, or you can touch **Erase** to delete it or touch **Save** to save the picture to the gallery.
4. To exit the camera, press the  **Home** key on the front of the phone.

Record Video

1. From the home screen, press and hold the **Camera/Camcorder** key  on the right side of the phone. The camcorder is now active.

Note: Alternatively to launch the camera, press but do not hold the Camera/Camcorder key .

2. Touch **Options** to choose specific video settings. Touch the navigation key up or down to advance to each setting category, and to make selections within each category.

The following categories are available:

- **Settings:** Allows you to customize your video settings.
 - **Color Effects:** Allows you to set this option from the following choices: Normal, Black & White, Antique and Negative.
 - **White Balance:** Auto, Sunny, Cloudy, Tungsten, or Fluorescent.
 - **Brightness:** Allows you to set the brightness of the screen display.
 - **Memory:** Allows you to select the location for saved videos. Save to phone or microSD™ card.
 - **Auto Name:** Allows you to set Auto Name to On or Off. The file is saved and file name is selected automatically.
 - **Icon Display:** Allows you to hide or view the camcorder icons in the display when recording a video. Display All, Partial, No Icons.
 - **Sound Effect:** Allows you to select the Start Sound and/or End Sound.
 - **Reset Settings:** Return camcorder options to default settings.
- **Recording Time:** Choose: Limit for Send (for sending video messages, up to 30 seconds), or For Save (up to 10 minutes).
- **Recording Light:** Allows you to set the recording light to Auto, On or Off.
- **Self Timer:** Off, 3 Seconds, 5 Seconds, 10 Seconds
- **Quality:** Fine, Normal or Economy.
- **Resolution:** Choose: 320X240 or 176X144 (for Video Msg).

- **Camera:** Switches from Camcorder to Camera.

3. Touch **REC** to begin recording. Touch **Pause** or **STOP** at anytime during the recording.
4. Touch **Save** or **Erase**.
5. To exit the camcorder, press the **Home** key on the front of the phone.

Note: If you receive an incoming call while using your camcorder, the video recording is stopped. You will be presented with the call **Ignore / Accept** screen. If you ignore the call, then you are given the choice to **Save, Play** or **Erase** the video. If you accept the call, then your video is auto-saved and the camcorder application exits in the background.



Note: If the battery level becomes too low while you are recording, the recording is stopped and the video is auto-saved. The low battery indicator will be displayed and you will exit from the camcorder application. If your battery is too low, your Glyde™ will power down without saving the video.

Note: If you receive a text message, a multi-media message or a voicemail while you are recording, the video recording is stopped. You are given the choice to **View Now** or **View Later**. If you choose later, you are given the chance to **Save, Play** or **Erase** the video. If you want to view the message now, the video is auto-saved and the camera application exits in the background.

Online Album



Stores pictures and videos to your VZW Online Album.

Note: You must first setup your account on the Verizon Wireless website: www.verizonwireless.com before establishing a connection.

1. From the Home screen, touch  **MENU**.
2. Touch  **Get It Now**.
3. Touch **2. Picture & Video**.
4. Touch **7. Online Album**. The VZW Online Album sign-on screen displays.
5. Enter your **Mobile Number** and **Password**. Touch **LOGIN**.
You are now connected to your online album.

Games



Select from several fun and interesting applications or a broad category of games that you can play on your phone.

1. From the Home screen, touch  **MENU**.
2. Touch  **Get It Now**.
3. Touch **3. Games**.
4. Touch **1. Shop Games**.

The online catalog of Games displays.

5. Touch to make a selection.
6. Choose the charge, either **Subscription** or **Unlimited**. Follow in screen prompts to apply.

Internet Browser

1. From the Home screen, touch  **MENU**.
2. Touch  **Get It Now**.
3. Touch **4. Internet Browser**.



Note: A popup will display to notify that you must "**PRESS LOCK KEY ON SIDE TO LOCK YOUR SCREEN**". Select OK to continue (and you will see this prompt the next time), or select Don't Show Again (to not see this prompt again when accessing the internet browser). Remember that the Lock key is the Power/Lock/Unlock key .

4. The VZW Home portal is launched and a pop up screen with available applications displayed.
5. Touch to browse the categories.
6. Once the desired category is selected, touch to enter the category list.

Note: For a description of the Browser command bar buttons, and main functions in the browser, see "*Browser*" on page 114.



Browse & Download

Download applications that keep you in touch with the world, keep you organized, and help you find the coolest spots.

1. From the Home screen, touch  **MENU**.
2. Touch  **Get It Now**.
3. Touch **5. Browse & Download**.
4. Touch **1. Browse & Shop**.
5. Touch to select the application you wish to download.
6. Follow on screen subscription prompts. The download process begins.
7. At the “App installed successfully. Would you like to run it?” prompt, touch **Yes** to launch application, or **No** to return to category list.

Note: The **Browse & Download** menu will display all downloaded applications, with the most current download first.

Extras

1. From the Home screen, touch  **MENU**.
2. Touch  **Get It Now**.
3. Touch **6. Extras**.
4. Touch **1. Shop Extras**. Touch the application you wish to download. Follow on screen subscription prompts. The download process begins.
5. At the “App installed successfully. Would you like to run it?” prompt, touch **Yes** to launch application, or **No** to return to category list.

Section 10: Tools

The topics covered in this section allow you to schedule appointments, view the calendar, set an alarm, view time zones, take notes, and perform simple math calculations.



Voice Commands







For more information, refer to “Voice Commands” on page 34.

Calculator

You can perform calculations including addition, subtraction, multiplication and division using your phone.

Normal



1. From the Home screen, touch  **MENU**.
2. Touch  **Settings & Tools**.
3. Touch **2. Tools, 2. Calculator, 1. Normal**. The **Calculator** opens.
4. Enter the first number in your equation using the touch keypad or QWERTY keyboard. Numbers can be up to eight digits total.
5. Touch  to display a pop-up menu which allows you to enter a special characters if desired.

6. Touch  to clear a single number or equation or touch  to clear the entire data entered.
7. Touch the function keys to set the type of calculation that you wish to perform. Your choices are as follows:
 -  Addition
 -  Subtraction
 -  Multiplication
 -  Division
8. Use the touch keypad to enter the second number into your equation.
9. Touch  to perform the calculation and view the results.

Tip

Calculates the tip and how much each person should pay.

Note: The following steps outline tip calculations using the touch keypad.

1. From the Home screen, touch  **MENU**.
2. Touch  **Settings & Tools**.

3. Touch **2. Tools, 2. Calculator, 2. Tip**. The **Tip Calculator** opens.
4. Touch each field to populate:
 - **Bill**: enter the amount of the bill and touch **NEXT**.
 - **Tip**: enter tip percentage and touch **NEXT**.
 - **# Paying**: enter the amount of people paying and touch **DONE**.
5. The calculator will display the tip, total bill including the tip, and the share of the bill for each person.
6. To clear all fields, touch **REMOVE**.

Converter

The Converter provides several conversion categories.

1. From the Home screen, touch **MENU**.
2. Touch **Settings & Tools**.
3. Touch **2. Tools, 2. Calculator, 3. Converter**. The following categories are displayed:
 - Temperature
 - Length
 - Weight
 - Area
 - Volume

- Currency

4. Touch the desired category type.

There are three fields at the top of the display: category type (1), sub-category (2), with the units of measure or money, and the entry field (3).

The units of measure for the conversion (4), is near the bottom of the display.

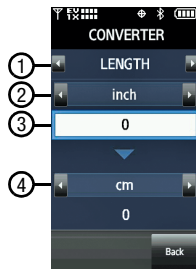

5. At the second field, (sub-category), touch the left **◀** or right **▶** arrows to choose a unit of measure or money. At the fourth field, choose a unit for the conversion.
6. Touch the entry field. Using the touch keypad, enter the amount and press **DONE**. The amount will display at the fourth field. When using the QWERTY keyboard, you do not need to touch the entry field. Enter the value using number keys. The amount will display automatically.

Note: You may touch  at any time while in the entry field to cancel and return to the Converter menu screen.

Calendar

Schedule up to eight events for any day by indicating each event's start and end time. Set alarms for events so that you can be alerted before an event takes place. Events scheduled for future dates automatically appear on your Today events schedule for the present day.

Note: Any event scheduled within the next 24 hours will cause the Calendar icon to be illuminated on the Event Status bar and will appear on the Event Manager screen.







Add a new event



1. From the Home screen, touch  **MENU**.
2. Touch  **Settings & Tools**.
3. Touch **2. Tools**, **3. Calendar**. The calendar appears in the display with the current date highlighted.
4. To view available options, touch . A menu displays that contains the following menu items.
 - **Weekly:** View the current week.
 - **Go To Date:** Go to any date that you specify.

- **Go to Today:** View today's events.
 - **Erase Old:** Select a past event to delete.
 - **Erase All:** Delete all events in your calendar.
5. Select an option or touch .
 6. At the calendar display, touch  to add a new event.
 7. Touch the field below **Appointment Name**. Enter the name in the field using the touch keypad or the QWERTY keyboard and touch . Touch the following fields to enter the appropriate information:
 - **Start Date:** Enter the start date for the event.
 - **Start Time:** Enter the start time for the event.
 - am/pm: Select from am or pm for the start time.
 - **End Date:** Enter the end date for the event.
 - **End Time:** Enter the end time for the event.
 - am/pm: Select from am or pm for the end time.
 - **Recurrence:** Select the frequency of the event.
 - **Alert:** Sets the alarm for the event. Select from Tone, Vibrate, or Light Only.
 - **Reminder:** Set a reminder before the event. Select Off, Once, Every 2 Minutes, Every 15 Minutes.
 - **Alert Time:** Set the Alert Time to sound before the event takes place.

8. Fill in and select event details by touching the field and making your selections.
9. Touch . The event is saved.

View an event

1. From the Home screen, touch  **MENU**.
2. Touch  **Settings & Tools**.
3. Touch **2. Tools, 3. Calendar**. The calendar displays.
4. Touch to select the date containing the event that you wish to view or touch . In the menu that displays, touch **Go To Date**.
5. Enter the desired date in the box, then touch . The month that you entered appears in the display, with the event date highlighted.
6. Touch the event you wish to open. The event information displays.
7. To edit the event, touch .
8. Make all of the necessary edits by touching the desired fields and touch .



9. To see the selected date in a month view, touch  and touch **1. Monthly**.
10. To see the selected date in a week view, touch  **Options** and then touch **2. Weekly**.
11. To erase the current event, touch  then touch **3. Erase**. 'ERASE THIS EVENT?' displays. Touch **Yes** to erase, or **No** to cancel.









Alarm Clock

Your phone has an alarm clock that can be set to go off once, or recur daily at a specific time. Once set, the alarm clock is easy to change or turn off.

Note: Any event scheduled within the next 24 hours will cause the Calendar icon to be illuminated on the Event Status bar and will appear on the Event Manager screen.





Set An Alarm

1. From the Home screen, touch  **MENU**.
2. Touch  **Settings & Tools**.
3. Touch **2. Tools, 4. Alarm Clock**. The following options appear in the display:
 - **Alarm 1**

- **Alarm 2**
 - **Alarm 3**
4. Touch the alarm that you wish to enable.
 5. At the top field, touch the left  or right  arrows to select **Alarm On** or **Alarm Off**.
 6. Touch the **Time** field. Enter the alarm time using the touch keypad or QWERTY keyboard and touch . Touch the left  or right  arrows to select **am** or **pm**.
 7. Touch the left  or right  arrows to select the **Frequency** field. The following options are available:
 - **Once**: The alarm sounds only once, at the time specified.
 - **Daily**: The alarm sounds every day at the time specified.
 - **Mon-Fri**: The alarm sounds Monday through Friday at the time specified.
 - **Weekends**: The alarm sounds Saturday through Sunday at the time specified.
 8. Touch the left  or right  arrows to select the **Ringer** option. Select **Tone**, **Vibrate**, or **Light Only**.
 9. If you selected **Tone**, **VZW Default Tone** is the default ringer tone. Touch **VZW Default Tone** to select a different tone from **My Ringtones**. Touch a ringer option to select a tone.

10. When all fields have correct information entered, touch  to save your settings.

Disable an alarm before it sounds

1. From the Home screen, touch  **MENU**.
2. Touch  **Settings & Tools**.
3. Touch **2. Tools**, **4. Alarm Clock**. The **Alarm Clock** menu displays.
4. Touch the alarm that you wish to turn off.
5. Touch  to reset the alarm.
Alternately, you can touch  to reset all alarms without first selecting a desired alarm.

Snooze







When an alarm sounds, a menu screen displays that allows you to either turn the alarm off or to have the alarm ring again after 5 minutes. To use the snooze feature, follow these steps:

1. Set one of your phone's 3 alarms. For more information, refer to "Set An Alarm" on page 110.

2. When an alarm sounds, touch **Snooze** or **Dismiss**. To snooze, touch **Snooze** to set it to ring again after 5 minutes. Or, touch **Dismiss** to turn the alarm off. The alarm turns off and the Home screen displays.

Stop Watch

This feature allows you to use a stopwatch. You can use it to measure total elapsed time and splits.

1. From the Home screen, touch  **MENU**.
2. Touch  **Settings & Tools**.
3. Touch **2. Tools**, **5. Stop Watch**. The **Stop Watch** appears in the display.
4. Touch  to start the stopwatch. Touch  to record split times.
5. Touch  to stop stopwatch.
6. Touch  to erase recorded stopwatch time.
7. Touch  to exit Stop Watch.

World Clock



World Clock allows you to view the time of day or night in any part of the world.

1. From the Home screen, touch  **MENU**.



2. Touch  **Settings & Tools**.
3. Touch **2. Tools**, **6. World Clock**.
4. Touch  to display city names.
5. Touch  to view the following options:
 - **Set As Local Time**: Sets the time according to the city chosen in the Cities field.
 - **Turn DST On**: Sets the Daylight Savings time option.
6. You can scroll through other cities by touching the navigation keys left  or right .
7. Touch  to exit World Clock.

Notepad



Create and store notes in Notepad. Return to Notepad anytime to review and edit your notes.

1. From the Home screen, touch  **MENU**.
2. Touch  **Settings & Tools**.
3. Touch **2. Tools**.
4. Scroll the screen up and touch **7. Notepad**.



If you have any stored notes, they appear as a list in the display. If this is your first time in Notepad, **No Notes** displays.

- To add a new note, touch  then enter the note using the touch keypad or the QWERTY keyboard.
- While entering a note, touch  to display a menu with the following text entry modes:
 - Word



Note: Word text entry option is only available when using the touch keypad. Word is not available when using the QWERTY keyboard.

- Abc
 - ABC
 - 123
 - Symbols
- Touch a text entry mode or touch  to exit the menu.
 - When you're finished entering details for the note, touch . The note is saved.



Review and Edit Notes

- From the Home screen, touch  **MENU**.
- Touch  **Settings & Tools**.
- Touch **2. Tools**.
- Scroll the screen up and touch **7. Notepad**.

The **Notepad** menu opens. If you have any stored notes, they appear as a list in the display.

- To edit a note, touch the note in the list. Touch  to make changes. Make your changes to the note and touch  to save changes.

Erase , Add New and Lock Notes

- With a note highlighted, touch . A menu with the following options appears in the display:
 - **Erase:** Allows you to erase an opened note. Press **Yes** to confirm deletion.
 - **Add New Note:** Allows you to add a new note.
 - **Lock/Unlock:** Allows you to lock the note to prevent accidental deletion or to unlock a locked note.
- Highlight an option, or touch  to exit the pop-up menu.

Section 11: Browser

Browser

Your Browser allows you to surf the web from your Samsung Glyde™. If you receive a call while using Browser, the web session is suspended during the call. Once the call ends, your Browser session resumes where you left off.

Note: This feature is currently unavailable outside of the United States. Only available within the Verizon Wireless Enhanced Services Area.

Any time the service indicator icon is visible, you are connected to the Internet and billed accordingly. Rates and prices vary according to your service contract. For further information on billing, contact Verizon Wireless.

Launching Browser

Note: This feature is currently unavailable outside of the United States. Only available within the Verizon Wireless Enhanced Services Area.

1. From the Home screen, touch  **MENU**.
2. Touch **Browser**  to launch the browser.
3. Browse the categories from the VZW Home portal and touch the appropriate browser command bar button to navigate the mobile web.



Browser Command Bar Buttons

At the bottom of the browser display contains the browser command bar buttons. The browser buttons have specific functions for navigating the mobile web.



How Browser Buttons Work

The following lists Browser buttons and their functions:

-  **Back button:** Touch once to back up one page. If a web page is loading, touch the back button to stop web page loading in progress. Touch to clear the last number, letter, or symbol entered.
-  **Home button:** Touch the Home button to return to the default home web page.
-  **Refresh button:** Touch the Refresh button to reload the current web page.

-  **Favorites button:** Touch the Favorites button to view a list of favorite web sites. Touch a favorite to launch the website.
-  **WWW button:** Touch the World Wide Web button to launch the screen for entering a URL site.
-  **Menu button:** Touch Menu button to view the menu list for the following options:
 - **Home:** Touch to return to home page.
 - **Add to Favorite:** Touch to save current website to favorites list.
 - **Edit Favorites:** Touch to launch View Favorites menu. Touch a favorite to Edit, Delete or Set As Home.
 - **Go To WWW:** Touch to launch the screen for entering a URL site. This option is similar to touching the WWW button.
 - **Show URL:** Touch to view the current website URL information.
 - **Zoom:** Touch to zoom in and out of the current web page by using the volume key, located on the right side of your Glyde™.
 - **Manage Memory:** Touch to launch manage memory screen with the following options: 1. Clear Cache, 2. Clear History and 3. Clear Cookies.
 - **Settings:** Touch to launch Settings screen with the following options; 1. Set Homepage, 2. Restart Browser, 3. Send Referrer, 4. View Mode, 5. Connection Time out, 6. Java Script and 7. Zoom mode. Touch an option to choose a setting.
 - **Advanced:** Touch to launch Advanced screen with the following options: 1. About, 2. History and 3. Encryption. Touch an option to view information.

Navigate the Web

When you use Browser, some of the items operate differently than on a normal menu or text screen.

Browser presents on-screen items in any of the following ways:

- Text or numeric input
- Links (embedded in content)
- Numbered options (some options may not be numbered)
- Simple text

You can act on the options or links by touching the appropriate selections or command bar buttons.

Links

Note: This feature is currently unavailable outside of the United States. Only available within the Verizon Wireless Enhanced Services Area.

Links can serve several purposes, such as jumping to a different page, to a different site, or initiating a phone call. Links are underlined ().

Place a call while using the Browser

Note: This feature is currently unavailable outside of the United States. Only available within the Verizon Wireless Enhanced Services Area.

You can place a call while using the Browser if the website supports this feature. Touch the appropriate link to call the number. The Internet connection terminates when you initiate the call. After you end the call, the Resume Browser screen displays.

Exit Browser

To exit the Browser, press the  **Home** key on the front of the phone to return to the Home screen.

Section 12: Health and Safety Information

This section outlines the safety precautions associated with using your Samsung Glyde™. These safety precautions should be followed to safely use your Glyde™.

Health and Safety Information

Exposure to Radio Frequency (RF) Signals

Certification Information (SAR)

Your wireless phone is a radio transmitter and receiver. It is designed and manufactured not to exceed the exposure limits for radio frequency (RF) energy set by the Federal Communications Commission (FCC) of the U.S. government.

These FCC exposure limits are derived from the recommendations of two expert organizations, the National Council on Radiation Protection and Measurement (NCRP) and the Institute of Electrical and Electronics Engineers (IEEE).

In both cases, the recommendations were developed by scientific and engineering experts drawn from industry, government, and academia after extensive reviews of the scientific literature related to the biological effects of RF energy.

The exposure limit set by the FCC for wireless mobile phones employs a unit of measurement known as the Specific Absorption Rate (SAR). The SAR is a measure of the rate of

absorption of RF energy by the human body expressed in units of watts per kilogram (W/kg). The FCC requires wireless phones to comply with a safety limit of 1.6 watts per kilogram (1.6 W/kg).

The FCC exposure limit incorporates a substantial margin of safety to give additional protection to the public and to account for any variations in measurements.

SAR tests are conducted using standard operating positions accepted by the FCC with the phone transmitting at its highest certified power level in all tested frequency bands. Although the SAR is determined at the highest certified power level, the actual SAR level of the phone while operating can be well below the maximum value. This is because the phone is designed to operate at multiple power levels so as to use only the power required to reach the network. In general, the closer you are to a wireless base station antenna, the lower the power output.

Before a new model phone is available for sale to the public, it must be tested and certified to the FCC that it does not exceed the exposure limit established by the FCC. Tests for each model phone are performed in positions and locations (e.g. at the ear and worn on the body) as required by the FCC.

For body worn operation, this phone has been tested and meets FCC RF exposure guidelines when used with an accessory that

contains no metal and that positions the handset a minimum of 1.5 cm from the body.

Use of other accessories may not ensure compliance with FCC RF exposure guidelines.

The FCC has granted an Equipment Authorization for this mobile phone with all reported SAR levels evaluated as in compliance with the FCC RF exposure guidelines. The maximum SAR values for this model phone as reported to the FCC are:

- Head: 1.08 W/Kg.
- Body-worn: 0.878 W/Kg.

SAR information on this and other model phones can be viewed online at <http://www.fcc.gov/oet/ea>. To find information that pertains to a particular model phone, this site uses the phone FCC ID number which is usually printed somewhere on the case of the phone.

Sometimes it may be necessary to remove the battery pack to find the number. Once you have the FCC ID number for a particular phone, follow the instructions on the website and it should provide values for typical or maximum SAR for a particular phone. Additional product specific SAR information can also be obtained at www.fcc.gov/cgb/sar.

Samsung Mobile Products and Recycling

Samsung cares for the environment and encourages its customers to recycle Samsung mobile phones and genuine Samsung accessories.

Go to: <http://www.samsung.com/us/consumer/type/type.do?group=mobilephones&type=mobilephones> for more information.

UL Certified Travel Adapter

The Travel Adapter for this phone has met applicable UL safety requirements. Please adhere to the following safety instructions per UL guidelines.

FAILURE TO FOLLOW THE INSTRUCTIONS OUTLINED MAY LEAD TO SERIOUS PERSONAL INJURY AND POSSIBLE PROPERTY DAMAGE.

IMPORTANT SAFETY INSTRUCTIONS - SAVE THESE INSTRUCTIONS.

DANGER - TO REDUCE THE RISK OF FIRE OR ELECTRIC SHOCK, CAREFULLY FOLLOW THESE INSTRUCTIONS.

FOR CONNECTION TO A SUPPLY NOT IN NORTH AMERICA, USE AN ATTACHMENT PLUG ADAPTOR OF THE PROPER CONFIGURATION FOR THE POWER OUTLET. THIS POWER UNIT IS INTENDED TO BE CORRECTLY ORIENTATED IN A VERTICAL OR HORIZONTAL OR FLOOR MOUNT POSITION.

Consumer Information on Wireless Phones

The U.S. Food and Drug Administration (FDA) has published a series of Questions and Answers for consumers relating to radio frequency (RF) exposure from wireless phones. The FDA publication includes the following information:

What kinds of phones are the subject of this update?

The term wireless phone refers here to hand-held wireless phones with built-in antennas, often called "cell," "mobile," or "PCS" phones. These types of wireless phones can expose the user to measurable radio frequency energy (RF) because of the short distance between the phone and the user's head. These RF exposures are limited by Federal Communications Commission safety guidelines that were developed with the advice of FDA and other federal health and safety agencies.

When the phone is located at greater distances from the user, the exposure to RF is drastically lower because a person's RF exposure decreases rapidly with increasing distance from the source. The so-called "cordless phones," which have a base unit connected to the telephone wiring in a house, typically operate at far lower power levels, and thus produce RF exposures well within the FCC's compliance limits.

Do wireless phones pose a health hazard?

The available scientific evidence does not show that any health problems are associated with using wireless phones. There is no proof, however, that wireless phones are absolutely safe. Wireless phones emit low levels of radio frequency energy (RF) in the microwave range while being used. They also emit very low levels of RF when in the stand-by mode. Whereas high levels of RF can produce health effects (by heating tissue), exposure to low level RF that does not produce heating effects causes no known adverse health effects. Many studies of low level RF exposures have not found any biological effects. Some studies have suggested that some biological effects may occur, but such findings have not been confirmed by additional research. In some cases, other researchers have had difficulty in reproducing those studies, or in determining the reasons for inconsistent results.

What is FDA's role concerning the safety of wireless phones?

Under the law, FDA does not review the safety of radiation-emitting consumer products such as wireless phones before they can be sold, as it does with new drugs or medical devices. However, the agency has authority to take action if wireless phones are shown to emit radio frequency energy (RF) at a level that is hazardous to the user. In such a case, FDA could require the manufacturers of wireless phones to notify users of the

health hazard and to repair, replace or recall the phones so that the hazard no longer exists.

Although the existing scientific data do not justify FDA regulatory actions, FDA has urged the wireless phone industry to take a number of steps, including the following:

- Support needed research into possible biological effects of RF of the type emitted by wireless phones;
- Design wireless phones in a way that minimizes any RF exposure to the user that is not necessary for device function; and
- Cooperate in providing users of wireless phones with the best possible information on possible effects of wireless phone use on human health.

FDA belongs to an interagency working group of the federal agencies that have responsibility for different aspects of RF safety to ensure coordinated efforts at the federal level. The following agencies belong to this working group:

- National Institute for Occupational Safety and Health
- Environmental Protection Agency
- Federal Communications Commission
- Occupational Safety and Health Administration
- National Telecommunications and Information Administration

The National Institutes of Health participates in some interagency working group activities, as well.

FDA shares regulatory responsibilities for wireless phones with the Federal Communications Commission (FCC). All phones that are sold in the United States must comply with FCC safety guidelines that limit RF exposure. FCC relies on FDA and other health agencies for safety questions about wireless phones.

FCC also regulates the base stations that the wireless phone networks rely upon. While these base stations operate at higher power than do the wireless phones themselves, the RF exposures that people get from these base stations are typically thousands of times lower than those they can get from wireless phones.

Base stations are thus not the primary subject of the safety questions discussed in this document.

What are the results of the research done already?

The research done thus far has produced conflicting results, and many studies have suffered from flaws in their research methods. Animal experiments investigating the effects of radio frequency energy (RF) exposures characteristic of wireless phones have yielded conflicting results that often cannot be repeated in other laboratories. A few animal studies, however, have suggested that low levels of RF could accelerate the development of cancer in laboratory animals. However, many of the studies that showed increased tumor development used animals that had been genetically engineered or treated with

cancer-causing chemicals so as to be pre-disposed to develop cancer in absence of RF exposure. Other studies exposed the animals to RF for up to 22 hours per day. These conditions are not similar to the conditions under which people use wireless phones, so we don't know with certainty what the results of such studies mean for human health.

Three large epidemiology studies have been published since December 2000. Between them, the studies investigated any possible association between the use of wireless phones and primary brain cancer, glioma, meningioma, or acoustic neuroma, tumors of the brain or salivary gland, leukemia, or other cancers. None of the studies demonstrated the existence of any harmful health effects from wireless phones RF exposures.

However, none of the studies can answer questions about long-term exposures, since the average period of phone use in these studies was around three years.

What research is needed to decide whether RF exposure from wireless phones poses a health risk?

A combination of laboratory studies and epidemiological studies of people actually using wireless phones would provide some of the data that are needed. Lifetime animal exposure studies could be completed in a few years. However, very large numbers of animals would be needed to provide reliable proof of a cancer promoting effect if one exists. Epidemiological studies can

provide data that is directly applicable to human populations, but ten or more years' follow-up may be needed to provide answers about some health effects, such as cancer.

This is because the interval between the time of exposure to a cancer-causing agent and the time tumors develop - if they do - may be many, many years. The interpretation of epidemiological studies is hampered by difficulties in measuring actual RF exposure during day-to-day use of wireless phones. Many factors affect this measurement, such as the angle at which the phone is held, or which model of phone is used.

What is FDA doing to find out more about the possible health effects of wireless phone RF?

FDA is working with the U.S. National Toxicology Program and with groups of investigators around the world to ensure that high priority animal studies are conducted to address important questions about the effects of exposure to radio frequency energy (RF).

FDA has been a leading participant in the World Health Organization international Electromagnetic Fields (EMF) Project since its inception in 1996. An influential result of this work has been the development of a detailed agenda of research needs that has driven the establishment of new research programs around the world. The Project has also helped develop a series of public information documents on EMF issues.

FDA and Cellular Telecommunications & Internet Association (CTIA) have a formal Cooperative Research and Development Agreement (CRADA) to do research on wireless phone safety. FDA provides the scientific oversight, obtaining input from experts in government, industry, and academic organizations.

CTIA-funded research is conducted through contracts to independent investigators. The initial research will include both laboratory studies and studies of wireless phone users. The CRADA will also include a broad assessment of additional research needs in the context of the latest research developments around the world.

What steps can I take to reduce my exposure to radio frequency energy from my wireless phone?

If there is a risk from these products - and at this point we do not know that there is - it is probably very small. But if you are concerned about avoiding even potential risks, you can take a few simple steps to minimize your exposure to radio frequency energy (RF). Since time is a key factor in how much exposure a person receives, reducing the amount of time spent using a wireless phone will reduce RF exposure.

- If you must conduct extended conversations by wireless phone every day, you could place more distance between your body and the source of the RF, since the exposure level drops off dramatically with distance. For example, you could use a headset and carry the wireless phone

away from your body or use a wireless phone connected to a remote antenna.

Again, the scientific data do not demonstrate that wireless phones are harmful. But if you are concerned about the RF exposure from these products, you can use measures like those described above to reduce your RF exposure from wireless phone use.

What about children using wireless phones?

The scientific evidence does not show a danger to users of wireless phones, including children and teenagers. If you want to take steps to lower exposure to radio frequency energy (RF), the measures described above would apply to children and teenagers using wireless phones. Reducing the time of wireless phone use and increasing the distance between the user and the RF source will reduce RF exposure.

Some groups sponsored by other national governments have advised that children be discouraged from using wireless phones at all. For example, the government in the United Kingdom distributed leaflets containing such a recommendation in December 2000.

They noted that no evidence exists that using a wireless phone causes brain tumors or other ill effects. Their recommendation to limit wireless phone use by children was strictly precautionary; it

was not based on scientific evidence that any health hazard exists.

Do hands-free kits for wireless phones reduce risks from exposure to RF emissions?

Since there are no known risks from exposure to RF emissions from wireless phones, there is no reason to believe that hands-free kits reduce risks. Hands-free kits can be used with wireless phones for convenience and comfort. These systems reduce the absorption of RF energy in the head because the phone, which is the source of the RF emissions, will not be placed against the head. On the other hand, if the phone is mounted against the waist or other part of the body during use, then that part of the body will absorb more RF energy. Wireless phones marketed in the U.S. are required to meet safety requirements regardless of whether they are used against the head or against the body. Either configuration should result in compliance with the safety limit.

Do wireless phone accessories that claim to shield the head from RF radiation work?

Since there are no known risks from exposure to RF emissions from wireless phones, there is no reason to believe that accessories that claim to shield the head from those emissions reduce risks. Some products that claim to shield the user from RF absorption use special phone cases, while others involve nothing

more than a metallic accessory attached to the phone. Studies have shown that these products generally do not work as advertised. Unlike "hand-free" kits, these so-called "shields" may interfere with proper operation of the phone. The phone may be forced to boost its power to compensate, leading to an increase in RF absorption. In February 2002, the Federal Trade Commission (FTC) charged two companies that sold devices that claimed to protect wireless phone users from radiation with making false and unsubstantiated claims.

According to FTC, these defendants lacked a reasonable basis to substantiate their claim.

What about wireless phone interference with medical equipment?

Radio frequency energy (RF) from wireless phones can interact with some electronic devices. For this reason, FDA helped develop a detailed test method to measure electromagnetic interference (EMI) of implanted cardiac pacemakers and defibrillators from wireless telephones. This test method is now part of a standard sponsored by the Association for the Advancement of Medical Instrumentation (AAMI). The final draft, a joint effort by FDA, medical device manufacturers, and many other groups, was completed in late 2000. This standard will allow manufacturers to ensure that cardiac pacemakers and defibrillators are safe from wireless phone EMI. FDA has tested

wireless phones and helped develop a voluntary standard sponsored by the Institute of Electrical and Electronic Engineers (IEEE). This standard specifies test methods and performance requirements for hearing aids and wireless phones so that no interference occurs when a person uses a compatible phone and a compatible hearing aid at the same time. This standard was approved by the IEEE in 2000.

FDA continues to monitor the use of wireless phones for possible interactions with other medical devices. Should harmful interference be found to occur, FDA will conduct testing to assess the interference and work to resolve the problem.

Additional information on the safety of RF exposures from various sources can be obtained from the following organizations (Updated 12/1/2006):

- FCC RF Safety Program:
<http://www.fcc.gov/oet/rfsafety/>
- Environmental Protection Agency (EPA):
<http://www.epa.gov/radiation/>
- Occupational Safety and Health Administration's (OSHA):
<http://www.osha.gov/SLTC/radiofrequencyradiation/index.html>
- National Institute for Occupational Safety and Health (NIOSH):
<http://www.cdc.gov/niosh/homepage.html>
- World Health Organization (WHO):
<http://www.who.int/peh-emf/>

- International Commission on Non-Ionizing Radiation Protection:
<http://www.icnirp.de>
- National Radiation Protection Board (UK):
<http://www.hpa.org.uk/radiation>
- US Food and Drug Administration
<http://www.fda.gov/cellphones>

Road Safety

Your wireless phone gives you the powerful ability to communicate by voice, almost anywhere, anytime. But an important responsibility accompanies the benefits of wireless phones, one that every user must uphold.

When driving a car, driving is your first responsibility. When using your wireless phone behind the wheel of a car, practice good common sense and remember the following tips:

1. Get to know your wireless phone and its features, such as speed dial and redial. If available, these features help you to place your call without taking your attention off the road.
2. When available, use a hands-free device. If possible, add an additional layer of convenience and safety to your wireless phone with one of the many hands free accessories available today.

3. Position your wireless phone within easy reach. Be able to access your wireless phone without removing your eyes from the road. If you get an incoming call at an inconvenient time, let your voice mail answer it for you.
4. Let the person you are speaking with know you are driving; if necessary, suspend the call in heavy traffic or hazardous weather conditions. Rain, sleet, snow, ice and even heavy traffic can be hazardous.
5. Do not take notes or look up phone numbers while driving. Jotting down a "to do" list or flipping through your address book takes attention away from your primary responsibility, driving safely.
6. Dial sensibly and assess the traffic; if possible, place calls when you are not moving or before pulling into traffic. Try to plan calls when your car will be stationary. If you need to make a call while moving, dial only a few numbers, check the road and your mirrors, then continue.
7. Do not engage in stressful or emotional conversations that may be distracting. Make people you are talking with aware you are driving and suspend conversations that have the potential to divert your attention from the road.
8. Use your wireless phone to call for help. Dial 9-1-1 or other local emergency number in the case of fire, traffic accident or medical emergencies.
9. Use your wireless phone to help others in emergencies. If you see an auto accident, crime in progress or other serious emergency where lives are in danger, call 9-1-1 or other local emergency number, as you would want others to do for you.
10. Call roadside assistance or a special non-emergency wireless assistance number when necessary. If you see a broken-down vehicle posing no serious hazard, a broken traffic signal, a minor traffic accident where no one appears injured, or a vehicle you know to be stolen, call roadside assistance or other special non-emergency number.

"The wireless industry reminds you to use your phone safely when driving."

For more information, please call 1-888-901-SAFE, or visit our web-site www.ctia.org.

Important!: If you are using a handset other than a standard numeric keypad, please call 1-888-901-7233.

Provided by the Cellular Telecommunications & Internet Association.

Responsible Listening

Caution!: Avoid potential hearing loss.

Damage to hearing occurs when a person is exposed to loud sounds over time. The risk of hearing loss increases as sound is played louder and for longer durations. Prolonged exposure to loud sounds (including music) is the most common cause of preventable hearing loss. Some scientific research suggests that using portable audio devices, such as portable music players and cellular telephones, at high volume settings for long durations may lead to permanent noise-induced hearing loss. This includes the use of headphones (including headsets, earbuds, and Bluetooth or other wireless devices). Exposure to very loud sound has also been associated in some studies with tinnitus (a ringing in the ear), hypersensitivity to sound and distorted hearing.

Individual susceptibility to noise-induced hearing loss and potential hearing problem varies. Additionally, the amount of sound produced by a portable audio device varies depending on the nature of the sound, the device settings, and the headphones that are used. As a result, there is no single volume setting that is appropriate for everyone or for every combination of sound, settings and equipment.

You should follow some commonsense recommendations when using any portable audio device:

- Set the volume in a quiet environment and select the lowest volume at which you can hear adequately.
- When using headphones, turn the volume down if you cannot hear the people speaking near you or if the person sitting next to you can hear what you are listening to.
- Do not turn the volume up to block out noisy surroundings. If you choose to listen to your portable device in a noisy environment, you noise-cancelling headphones to block out background environmental noise. By blocking background environment noise, noise cancelling headphones should allow you to hear the music at lower volumes than when using earbuds.
- Limit the amount of time you listen. As the volume increases, less time is required before you hearing could be affected.

- Avoid using headphones after exposure to extremely loud noises, such as rock concerts, that might cause temporary hearing loss. Temporary hearing loss might cause unsafe volumes to sound normal.
- Do not listen at any volume that causes you discomfort. If you experience ringing in your ears, hear muffled speech or experience any temporary hearing difficulty after listening to your portable audio device, discontinue use and consult your doctor.

You can obtain additional information on this subject from the following sources:

American Academy of Audiology

11730 Plaza American Drive, Suite 300

Reston, VA 20190

Voice: (800) 222-2336

Email: info@audiology.org

Internet: <http://www.audiology.org>

National Institute on Deafness and Other Communication Disorders

National Institutes of Health

31 Center Drive, MSC 2320

Bethesda, MD 20892-2320

Voice: (301) 496-7243

Email: nidcdinfo@nih.gov

Internet: <http://www.cdc.gov/niosh/topics/noise/default.html>

National Institute for Occupational Safety and Health

Hubert H. Humphrey Bldg.

200 Independence Ave., SW

Washington, DC 20201

Voice: 1-800-35-NIOSH (1-800-356-4647)

Internet: <http://www.cdc.gov/niosh/topics/noise/default.html>

Operating Environment

Remember to follow any special regulations in force in any area and always switch your phone off whenever it is forbidden to use it, or when it may cause interference or danger.

When connecting the phone or any accessory to another device, read its user's guide for detailed safety instructions. Do not connect incompatible products.

As with other mobile radio transmitting equipment, users are advised that for the satisfactory operation of the equipment and for the safety of personnel, it is recommended that the equipment should only be used in the normal operating position (held to your ear with the antenna pointing over your shoulder if you are using an external antenna).

Using Your Phone Near Other Electronic Devices

Most modern electronic equipment is shielded from radio frequency (RF) signals. However, certain electronic equipment may not be shielded against the RF signals from your wireless phone. Consult the manufacturer to discuss alternatives.

Implantable Medical Devices

A minimum separation of six (6) inches should be maintained between a handheld wireless phone and an implantable medical device, such as a pacemaker or implantable cardioverter defibrillator, to avoid potential interference with the device.

Persons who have such devices:

- Should ALWAYS keep the phone more than six (6) inches from their implantable medical device when the phone is turned ON;
- Should not carry the phone in a breast pocket;
- Should use the ear opposite the implantable medical device to minimize the potential for interference;

- Should turn the phone OFF immediately if there is any reason to suspect that interference is taking place.
- Should read and follow the directions from the manufacturer of your implantable medical device. If you have any questions about using your wireless phone with such a device, consult your health care provider.

For more information see:

<http://www.fcc.gov/oet/rfsafety/rf-faqs.html>

FCC Hearing-Aid Compatibility (HAC) Regulations for Wireless Devices

On July 10, 2003, the U.S. Federal Communications Commission (FCC) Report and Order in WT Docket 01-309 modified the exception of wireless phones under the Hearing Aid Compatibility Act of 1988 (HAC Act) to require digital wireless phones be compatible with hearing-aids.

The intent of the HAC Act is to ensure reasonable access to telecommunications services for persons with hearing disabilities.

While some wireless phones are used near some hearing devices (hearing aids and cochlear implants), users may detect a buzzing, humming, or whining noise. Some hearing devices are more immune than others to this interference noise, and phones also vary in the amount of interference they generate.

The wireless telephone industry has developed a rating system for wireless phones, to assist hearing device users find phones that may be compatible with their hearing devices. Not all phones have been rated. Phones that are rated have the rating on their box or a label located on the box.

The ratings are not guarantees. Results will vary depending on the user's hearing device and hearing loss. If your hearing device happens to be vulnerable to interference, you may not be able to use a rated phone successfully. Trying out the phone with your hearing device is the best way to evaluate it for your personal needs.

M-Ratings: Phones rated M3 or M4 meet FCC requirements and are likely to generate less interference to hearing devices than phones that are not labeled. M4 is the better/higher of the two ratings.

T-Ratings: Phones rated T3 or T4 meet FCC requirements and are likely to generate less interference to hearing devices than phones that are not labeled. T4 is the better/higher of the two ratings.

Hearing devices may also be rated. Your hearing device manufacturer or hearing health professional may help you find this rating. Higher ratings mean that the hearing device is relatively immune to interference noise. The hearing aid and wireless phone rating values are then added together. A sum of 5

is considered acceptable for normal use. A sum of 6 is considered for best use.

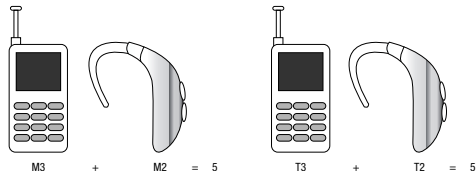

In the above example, if a hearing aid meets the M2 level rating and the wireless phone meets the M3 level rating, the sum of the two values equal M5. This is synonymous for T ratings. This should provide the hearing aid user with "normal usage" while using their hearing aid with the particular wireless phone. "Normal usage" in this context is defined as a signal quality that is acceptable for normal operation.

The M mark is intended to be synonymous with the U mark. The T mark is intended to be synonymous with the UT mark. The M and T marks are recommended by the Alliance for Telecommunications Industries Solutions (ATIS). The U and UT marks are referenced in Section 20.19 of the FCC Rules.

The HAC rating and measurement procedure are described in the American National Standards Institute (ANSI) C63.19 standard.

Other Medical Devices

If you use any other personal medical devices, consult the manufacturer of your device to determine if it is adequately shielded from external RF energy. Your physician may be able to assist you in obtaining this information. Switch your phone off in health care facilities when any regulations posted in these areas instruct you to do so. Hospitals or health care facilities may be using equipment that could be sensitive to external RF energy.

Vehicles

RF signals may affect improperly installed or inadequately shielded electronic systems in motor vehicles. Check with the manufacturer or its representative regarding your vehicle. You should also consult the manufacturer of any equipment that has been added to your vehicle.

Posted Facilities

Switch your phone off in any facility where posted notices require you to do so.

Potentially Explosive Environments

Switch your phone off when in any area with a potentially explosive atmosphere and obey all signs and instructions. Sparks

in such areas could cause an explosion or fire resulting in bodily injury or even death.

Users are advised to switch the phone off while at a refueling point (service station). Users are reminded of the need to observe restrictions on the use of radio equipment in fuel depots (fuel storage and distribution areas), chemical plants or where blasting operations are in progress.

Areas with a potentially explosive atmosphere are often but not always clearly marked. They include below deck on boats, chemical transfer or storage facilities, vehicles using liquefied petroleum gas (such as propane or butane), areas where the air contains chemicals or particles, such as grain, dust or metal powders, and any other area where you would normally be advised to turn off your vehicle engine.

Emergency Calls

This phone, like any wireless phone, operates using radio signals, wireless and landline networks as well as user-programmed functions, which cannot guarantee connection in all conditions. Therefore, you should never rely solely on any wireless phone for essential communications (medical emergencies, for example).

Remember, to make or receive any calls the phone must be switched on and in a service area with adequate signal strength. Emergency calls may not be possible on all wireless phone

networks or when certain network services and/or phone features are in use. Check with local service providers.

To make an emergency call:

1. If the phone is not on, switch it on.
2. Key in the emergency number for your present location (for example, 911 or other official emergency number).
Emergency numbers vary by location.
3. Press the **SEND** key.

If certain features are in use (call barring, for example), you may first need to deactivate those features before you can make an emergency call. Consult this document and your local cellular service provider.

When making an emergency call, remember to give all the necessary information as accurately as possible. Remember that your phone may be the only means of communication at the scene of an accident; do not cut off the call until given permission to do so.

Restricting Children's access to your Phone

Your phone is not a toy. Children should not be allowed to play with it because they could hurt themselves and others, damage the phone or make calls that increase your phone bill.

FCC Notice and Cautions

FCC Notice

The phone may cause TV or radio interference if used in close proximity to receiving equipment. The FCC can require you to stop using the phone if such interference cannot be eliminated.

Vehicles using liquefied petroleum gas (such as propane or butane) must comply with the National Fire Protection Standard (NFPA-58). For a copy of this standard, contact the National Fire Protection Association, One Batterymarch Park, Quincy, MA 02269, Attn: Publication Sales Division.

Cautions

Any changes or modifications to your phone not expressly approved in this document could void your warranty for this equipment, and void your authority to operate this equipment. Only use approved batteries, antennas and chargers. The use of any unauthorized accessories may be dangerous and void the phone warranty if said accessories cause damage or a defect to the phone.

Although your phone is quite sturdy, it is a complex piece of equipment and can be broken. Avoid dropping, hitting, bending or sitting on it.

Other Important Safety Information

- Only qualified personnel should service the phone or install the phone in a vehicle. Faulty installation or service may be dangerous and may invalidate any warranty applicable to the device.
- Check regularly that all wireless phone equipment in your vehicle is mounted and operating properly.
- Do not store or carry flammable liquids, gases or explosive materials in the same compartment as the phone, its parts or accessories.
- For vehicles equipped with an air bag, remember that an air bag inflates with great force. Do not place objects, including both installed or portable wireless equipment in the area over the air bag or in the air bag deployment area. If wireless equipment is improperly installed and the air bag inflates, serious injury could result.
- Switch your phone off before boarding an aircraft. The use of wireless phone in aircraft is illegal and may be dangerous to the aircraft's operation.
- Failure to observe these instructions may lead to the suspension or denial of telephone services to the offender, or legal action, or both.

Product Performance

Getting the Most Out of Your Signal Reception

The quality of each call you make or receive depends on the signal strength in your area. Your phone informs you of the current signal strength by displaying a number of bars next to the

signal strength icon. The more bars displayed, the stronger the signal.

If you're inside a building, being near a window may give you better reception.

Understanding the Power Save Feature

If your phone is unable to find a signal after searching, a Power Save feature is automatically activated. If your phone is active, it periodically rechecks service availability or you can check it yourself by pressing any key.

Anytime the Power Save feature is activated, a message displays on the screen. When a signal is found, your phone returns to standby mode.

Understanding How Your Phone Operates

Your phone is basically a radio transmitter and receiver. When it's turned on, it receives and transmits radio frequency (RF) signals. When you use your phone, the system handling your call controls the power level. This power can range from 0.006 watts to 0.2 watts in digital mode.

Maintaining Your Phone's Peak Performance

For the best care of your phone, only authorized personnel should service your phone and accessories. Faulty service may void the warranty.

There are several simple guidelines to operating your phone properly and maintaining safe, satisfactory service.

- To ensure that the Hearing Aid Compatibility rating for your phone is maintained, secondary transmitters such as Bluetooth and WLAN components must be disabled during a call. For more information, refer to *“Turning Bluetooth On or Off”* on page 73.
- If your phone is equipped with an external antenna, hold the phone with the antenna raised, fully-extended and over your shoulder.
- Do not hold, bend or twist the phone's antenna, if applicable.
- Do not use the phone if the antenna is damaged.
- If your phone is equipped with an internal antenna, obstructing the internal antenna could inhibit call performance.
- Speak directly into the phone's receiver.
- Avoid exposing your phone and accessories to rain or liquid spills. If your phone does get wet, immediately turn the power off and remove the battery. If it is inoperable, call Customer Care for service.

Availability of Various Features/Ring Tones

Many services and features are network dependent and may require additional subscription and/or usage charges. Not all features are available for purchase or use in all areas. Downloadable Ring Tones may be available at an additional cost. Other conditions and restrictions may apply. See your service provider for additional information.

Battery Standby and Talk Time

Standby and talk times will vary depending on phone usage patterns and conditions. Battery power consumption depends on factors such as network configuration, signal strength, operating temperature, features selected, frequency of calls, and voice, data, and other application usage patterns.

Battery Precautions

- Avoid dropping the cell phone. Dropping it, especially on a hard surface, can potentially cause damage to the phone and battery. If you suspect damage to the phone or battery, take it to a service center for inspection.
- Never use any charger or battery that is damaged in any way.
- Do not modify or remanufacture the battery as this could result in serious safety hazards.
- If you use the phone near the network's base station, it uses less power; talk and standby time are greatly affected by the signal strength on the cellular network and the parameters set by the network operator.
- Follow battery usage, storage and charging guidelines found in the user's guide.
- Battery charging time depends on the remaining battery charge and the type of battery and charger used. The battery can be charged and discharged hundreds of times, but it will gradually wear out. When the

operation time (talk time and standby time) is noticeably shorter than normal, it is time to buy a new battery.

- If left unused, a fully charged battery will discharge itself over time.
- Use only Samsung-approved batteries and recharge your battery only with Samsung-approved chargers. When a charger is not in use, disconnect it from the power source. Do not leave the battery connected to a charger for more than a week, since overcharging may shorten its life.
- Do not use incompatible cell phone batteries and chargers. Some Web sites and second-hand dealers, not associated with reputable manufacturers and carriers, might be selling incompatible or even counterfeit batteries and chargers. Consumers should purchase manufacturer or carrier recommended products and accessories. If unsure about whether a replacement battery or charger is compatible, contact the manufacturer of the battery or charger.
- Misuse or use of incompatible phones, batteries, and charging devices could result in damage to the equipment and a possible risk of fire, explosion, leakage, or other serious hazard.
- Extreme temperatures will affect the charging capacity of your battery: it may require cooling or warming first.
- Do not leave the battery in hot or cold places, such as in a car in summer or winter conditions, as you will reduce the capacity and lifetime of the battery. Always try to keep the battery at room temperature. A phone with a hot or cold battery may temporarily not work, even when the battery is fully charged. Li-ion batteries are

particularly affected by temperatures below 0 °C (32 °F).

- Do not place the phone in areas that may get very hot, such as on or near a cooking surface, cooking appliance, iron, or radiator.
- Do not get your phone or battery wet. Even though they will dry and appear to operate normally, the circuitry could slowly corrode and pose a safety hazard.
- Do not short-circuit the battery. Accidental short-circuiting can occur when a metallic object (coin, clip or pen) causes a direct connection between the + and - terminals of the battery (metal strips on the battery), for example when you carry a spare battery in a pocket or bag. Short-circuiting the terminals may damage the battery or the object causing the short-circuiting.
- Do not permit a battery out of the phone to come in contact with metal objects, such as coins, keys or jewelry.
- Do not crush, puncture or put a high degree of pressure on the battery as this can cause an internal short-circuit, resulting in overheating.
- Dispose of used batteries in accordance with local regulations. In some areas, the disposal of batteries in household or business trash may be prohibited. For safe disposal options for Li-ion batteries, contact your nearest Samsung authorized service center. Always recycle. Do not dispose of batteries in a fire.

Care and Maintenance

Your phone is a product of superior design and craftsmanship and should be treated with care. The suggestions below will help you fulfill any warranty obligations and allow you to enjoy this product for many years.

- Keep the phone and all its parts and accessories out of the reach of small children.
 - Keep the phone dry. Precipitation, humidity and liquids contain minerals that will corrode electronic circuits.
 - Do not use the phone with a wet hand. Doing so may cause an electric shock to you or damage to the phone.
 - Do not use or store the phone in dusty, dirty areas, as its moving parts may be damaged.
 - Do not store the phone in hot areas. High temperatures can shorten the life of electronic devices, damage batteries, and warp or melt certain plastics.
 - Do not store the phone in cold areas. When the phone warms up to its normal operating temperature, moisture can form inside the phone, which may damage the phone's electronic circuit boards.
 - Do not drop, knock or shake the phone. Rough handling can break internal circuit boards.
 - Do not use harsh chemicals, cleaning solvents or strong detergents to clean the phone. Wipe it with a soft cloth slightly dampened in a mild soap-and-water solution.
- Do not paint the phone. Paint can clog the device's moving parts and prevent proper operation.
 - Do not put the phone in or on heating devices, such as a microwave oven, a stove or a radiator. The phone may explode when overheated.
 - If your phone is equipped with an external antenna, use only the supplied or an approved replacement antenna. Unauthorized antennas or modified accessories may damage the phone and violate regulations governing radio devices.
 - If the phone, battery, charger or any accessory is not working properly, take it to your nearest qualified service facility. The personnel there will assist you, and if necessary, arrange for service.

Section 13: Warranty Information

Standard Limited Warranty

What is Covered and For How Long?

SAMSUNG TELECOMMUNICATIONS AMERICA, LLC ("SAMSUNG") warrants to the original purchaser ("Purchaser") that SAMSUNG's Phones and accessories ("Products") are free from defects in material and workmanship under normal use and service for the period commencing upon the date of purchase and continuing for the following specified period of time after that date:

Phone	1 Year
Batteries	1 Year
Leather Case	90 Days
Holster	90 Days
Other Phone Accessories	1 Year

What is Not Covered? This Limited Warranty is conditioned upon proper use of Product by Purchaser. This Limited Warranty does not cover: (a) defects or damage resulting from accident, misuse, abuse, neglect, unusual physical, electrical or electromechanical stress, or modification of any part of Product, including antenna, or cosmetic damage; (b) equipment that has the serial number

removed or made illegible; (c) any plastic surfaces or other externally exposed parts that are scratched or damaged due to normal use; (d) malfunctions resulting from the use of Product in conjunction with accessories, products, or ancillary/peripheral equipment not furnished or approved by SAMSUNG; (e) defects or damage from improper testing, operation, maintenance, installation, or adjustment; (f) installation, maintenance, and service of Product, or (g) Product used or purchased outside the United States or Canada.

This Limited Warranty covers batteries only if battery capacity falls below 80% of rated capacity or the battery leaks, and this Limited Warranty does not cover any battery if (i) the battery has been charged by a battery charger not specified or approved by SAMSUNG for charging the battery, (ii) any of the seals on the battery are broken or show evidence of tampering, or (iii) the battery has been used in equipment other than the SAMSUNG phone for which it is specified.

What are SAMSUNG's Obligations? During the applicable warranty period, SAMSUNG will repair or replace, at SAMSUNG's sole option, without charge to Purchaser, any defective component part of Product. To obtain service under this Limited Warranty, Purchaser must return Product to an authorized phone service

facility in an adequate container for shipping, accompanied by Purchaser's sales receipt or comparable substitute proof of sale showing the date of purchase, the serial number of Product and the sellers' name and address. To obtain assistance on where to deliver the Product, call Samsung Customer Care at 1-888-987-4357. Upon receipt, SAMSUNG will promptly repair or replace the defective Product. SAMSUNG may, at SAMSUNG's sole option, use rebuilt, reconditioned, or new parts or components when repairing any Product or replace Product with a rebuilt, reconditioned or new Product. Repaired/replaced leather cases, pouches and holsters will be warranted for a period of ninety (90) days. All other repaired/replaced Product will be warranted for a period equal to the remainder of the original Limited Warranty on the original Product or for 90 days, whichever is longer. All replaced parts, components, boards and equipment shall become the property of SAMSUNG.

If SAMSUNG determines that any Product is not covered by this Limited Warranty, Purchaser must pay all parts, shipping, and labor charges for the repair or return of such Product.

WHAT ARE THE LIMITS ON SAMSUNG'S WARRANTY/LIABILITY?

EXCEPT AS SET FORTH IN THE EXPRESS WARRANTY CONTAINED HEREIN, PURCHASER TAKES THE PRODUCT "AS IS," AND SAMSUNG MAKES NO WARRANTY OR REPRESENTATION AND THERE ARE NO CONDITIONS, EXPRESS OR IMPLIED, STATUTORY

OR OTHERWISE, OF ANY KIND WHATSOEVER WITH RESPECT TO THE PRODUCT, INCLUDING BUT NOT LIMITED TO:

- THE MERCHANTABILITY OF THE PRODUCT OR ITS FITNESS FOR ANY PARTICULAR PURPOSE OR USE;
- WARRANTIES OF TITLE OR NON-INFRINGEMENT;
- DESIGN, CONDITION, QUALITY, OR PERFORMANCE OF THE PRODUCT;
- THE WORKMANSHIP OF THE PRODUCT OR THE COMPONENTS CONTAINED THEREIN; OR
- COMPLIANCE OF THE PRODUCT WITH THE REQUIREMENTS OF ANY LAW, RULE, SPECIFICATION OR CONTRACT PERTAINING THERETO.

NOTHING CONTAINED IN THE INSTRUCTION MANUAL SHALL BE CONSTRUED TO CREATE AN EXPRESS WARRANTY OF ANY KIND WHATSOEVER WITH RESPECT TO THE PRODUCT. ALL IMPLIED WARRANTIES AND CONDITIONS THAT MAY ARISE BY OPERATION OF LAW, INCLUDING IF APPLICABLE THE IMPLIED WARRANTIES OF MERCHANTABILITY AND FITNESS FOR A PARTICULAR PURPOSE, ARE HEREBY LIMITED TO THE SAME DURATION OF TIME AS THE EXPRESS WRITTEN WARRANTY STATED HEREIN. SOME STATES/PROVINCES DO NOT ALLOW LIMITATIONS ON HOW LONG AN IMPLIED WARRANTY LASTS, SO THE ABOVE LIMITATION MAY NOT APPLY TO YOU. IN ADDITION, SAMSUNG SHALL NOT BE LIABLE FOR ANY DAMAGES OF ANY KIND RESULTING FROM THE PURCHASE, USE, OR MISUSE OF, OR INABILITY TO USE THE PRODUCT OR ARISING DIRECTLY OR INDIRECTLY FROM THE USE

OR LOSS OF USE OF THE PRODUCT OR FROM THE BREACH OF THE EXPRESS WARRANTY, INCLUDING INCIDENTAL, SPECIAL, CONSEQUENTIAL OR SIMILAR DAMAGES, OR LOSS OF ANTICIPATED PROFITS OR BENEFITS, OR FOR DAMAGES ARISING FROM ANY TORT (INCLUDING NEGLIGENCE OR GROSS NEGLIGENCE) OR FAULT COMMITTED BY SAMSUNG, ITS AGENTS OR EMPLOYEES, OR FOR ANY BREACH OF CONTRACT OR FOR ANY CLAIM BROUGHT AGAINST PURCHASER BY ANY OTHER PARTY. SOME STATES/PROVINCES DO NOT ALLOW THE EXCLUSION OR LIMITATION OF INCIDENTAL OR CONSEQUENTIAL DAMAGES, SO THE ABOVE LIMITATION OR EXCLUSION MAY NOT APPLY TO YOU. THIS WARRANTY GIVES YOU SPECIFIC LEGAL RIGHTS, AND YOU MAY ALSO HAVE OTHER RIGHTS, WHICH VARY FROM STATE TO STATE/PROVINCE TO PROVINCE. THIS LIMITED WARRANTY SHALL NOT EXTEND TO ANYONE OTHER THAN THE ORIGINAL PURCHASER OF THIS PRODUCT AND STATES PURCHASER'S EXCLUSIVE REMEDY. IF ANY PORTION OF THIS LIMITED WARRANTY IS HELD ILLEGAL OR UNENFORCEABLE BY REASON OF ANY LAW, SUCH PARTIAL ILLEGALITY OR UNENFORCEABILITY SHALL NOT AFFECT THE ENFORCEABILITY FOR THE REMAINDER OF THIS LIMITED WARRANTY WHICH PURCHASER ACKNOWLEDGES IS AND WILL ALWAYS BE CONSTRUED TO BE LIMITED BY ITS TERMS OR AS LIMITED AS THE LAW PERMITS. THE PARTIES UNDERSTAND THAT THE PURCHASER MAY USE THIRD-PARTY SOFTWARE OR EQUIPMENT

IN CONJUNCTION WITH THE PRODUCT. SAMSUNG MAKES NO WARRANTIES OR REPRESENTATIONS AND THERE ARE NO CONDITIONS, EXPRESS OR IMPLIED, STATUTORY OR OTHERWISE, AS TO THE QUALITY, CAPABILITIES, OPERATIONS, PERFORMANCE OR SUITABILITY OF ANY THIRDPARTY SOFTWARE OR EQUIPMENT, WHETHER SUCH THIRD-PARTY SOFTWARE OR EQUIPMENT IS INCLUDED WITH THE PRODUCT DISTRIBUTED BY SAMSUNG OR OTHERWISE, INCLUDING THE ABILITY TO INTEGRATE ANY SUCH SOFTWARE OR EQUIPMENT WITH THE PRODUCT. THE QUALITY, CAPABILITIES, OPERATIONS, PERFORMANCE AND SUITABILITY OF ANY SUCH THIRD-PARTY SOFTWARE OR EQUIPMENT LIE SOLELY WITH THE PURCHASER AND THE DIRECT VENDOR, OWNER OR SUPPLIER OF SUCH THIRD-PARTY SOFTWARE OR EQUIPMENT, AS THE CASE MAY BE.

This Limited Warranty allocates risk of Product failure between Purchaser and SAMSUNG, and SAMSUNG's Product pricing reflects this allocation of risk and the limitations of liability contained in this Limited Warranty. The agents, employees, distributors, and dealers of SAMSUNG are not authorized to make modifications to this Limited Warranty, or make additional warranties binding on SAMSUNG. Accordingly, additional statements such as dealer advertising or presentation, whether oral or written, do not constitute warranties by SAMSUNG and should not be relied upon.

Precautions for Transfer and Disposal

If data stored on this device is deleted or reformatted using the standard methods, the data only appears to be removed on a superficial level, and it may be possible for someone to retrieve and reuse the data by means of special software.

To avoid unintended information leaks and other problems of this sort, it is recommended that the device be returned to Samsung's Customer Care Center for an Extended File System (EFS) Clear which will eliminate all user memory and return all settings to default settings. Please contact the **Samsung Customer Care Center** for details.

Important! Please provide warranty information (proof of purchase) to Samsung's Customer Care Center in order to provide this service at no charge. If the warranty has expired on the device, charges may apply.

Customer Care Center:

1000 Klein St.

Plano, TX 75074

Toll Free Tel: 1.888.987.HELP (4357)

Samsung Telecommunications America, LLC:

1301 East Lookout Drive

Richardson, Texas 75082

Phone: 1-800-SAMSUNG (726-7864)

Important! If you are using a handset other than a standard numeric keypad, dial the numbers listed in brackets.

Phone: 1-888-987-HELP (4357)

©2008 Samsung Telecommunications America. All rights reserved.

No reproduction in whole or in part allowed without prior written approval. Specifications and availability subject to change without notice.

Numerics

- 1-touch dialing 47
- 2-touch dialing 47
- 3-touch dialing 47

A

Adding a Contact 39

Adding a Contact

Method 1- Creating a new Contact
from the Home screen 39

Method 2- Adding a number to a
new or existing Contact from the
Home screen 40

Alarm clock

snooze 111
turn off the alarm 111

Answer options 85

Auto retry 86

B

Battery

charging 9
indicator 4
removing 7

Bluetooth 72

about 72

Browse & Download 106

Browser 114

exit 116
launching 114
links 115

Browser Command Bar Buttons 114

C

Calendar

add a new event 109

Call Functions

answering a call 28
Recent Calls 29
roaming 33
Viewing Recent Call History 30

Call history

calls using 31
definition 29
deleting entry 32
icons 30
new contact 31
updating existing contact 31

Call Screen Layout 86

Camera

Take Picture 102

Change lock code 82

Changing Message Settings 69

**Changing Text Entry Mode with the
Slide-out Keyboard** 51

**Changing Text Entry Mode with the
Touch Keypad** 51

Clock Format 80

Command Bar Buttons 19

Command Keys 15

Contacts

deleting a contact entry 46
editing an existing contact entry 46
speed dialing 47

Create a New Group 44

**Creating a Text Message with the Slide-
out QWERTY Keyboard** 53

entering numbers using 123 mode
54
entering text using ABC mode 53
entering text using abc mode 54

entering text using quick text mode
55

entering text using symbols mode
54

Creating a Text Message with the Touch

Keypad 51

entering numbers using 123 mode
52

entering text using ABC mode 51

entering text using domain
extensions mode 53

entering text using quick text mode
53

entering text using symbols mode
52

entering text using word mode 52

Creating and Sending PICTURE Mes- sages 58

Creating and Sending TXT Messages 57

Creating and Sending VIDEO Messages 60

D

Dial Font Size 80

Dialing

one-touch 47

three-touch 47

two-touch 47

Dialog Boxes 20

Disable alarm 111

Display

backlight 78

Banner 78

language 81

Display Settings 77

Display settings

Banner 78

Downloading Music 91

Drafts

Create a Draft Text or Multimedia
Message 67

View and Edit Draft Messages 68

Drafts folder 67

E

Emergency Contacts 49

Emergency Contacts

Assigning an Emergency Contact -
From Contacts 49

Assigning an Emergency Contact
with a New Contact 50

Ending a call 27

Entering Text

using Abc & ABC Mode 53

using Word Mode 52

Extras 106

F

Finding a Contact Entry 46

Finding My Phone Number 49

G

Games 105

Get It Now 90

Get New Picture 98

Get New Ringtones 92

Getting Started 4

understanding this user manual 4

Groups

move entries from/to 43

send messages to 44

send Picture msg to 45

viewing 42

H

HAC 128

Health and Safety Information 117

I

Icons

alarm only 18

display 16

vibrate mode 18

Indicator

1X signal strength 16

Battery Level 17

Bluetooth Active 17

Bluetooth Connected 17

Bluetooth On 17

D signal strength 16

Data Call 16

Dormant 17

E911 17

EV signal strength 16

EV1X signal strength 16

Hold-Keys Lock 16

Location On 17

No service 16

Roaming 16

Speakerphone Off 17

Speakerphone On 17

SSL 16

Standalone 16

TTY 17

Voice Call 16

Voice Privacy 16

Installing the Battery 5

Internet Browser 105

K

Keyboard Navigation 22

Keypad Sounds 75

L

Language setting 81

Links 115

Living Wallpaper 79

Lock code, changing 82

Lock phone 83

M

Main Menu Screen Layout 19

Making a call 27

Making a Three-way Call 27

Manage My Pics 100

Memory Card

Installing 8

Removing 8

Menu Navigation

menu outline 23

Message Folders 63

Drafts 67

erase options 69

inbox 63

Sent 65

Messages, receive in call 63

Messaging 56

types of messages 56

microSD Card

formatting 91

Mobile IM 70

Mode

call answer 85

M-Ratings 129

Multimedia 90

Music

downloading 91

transferring from PC 95

Music & Tones 90

My Music 92

Playing Music 93

My Name Card 48

sending contact information (vCard)
to another Bluetooth-enabled
phone 48

My Ringtones 92**My Sounds** 94**N****Navigate the web** 115**Non-Supported Battery** 5**Notepad**

erase, add new and lock notes 113
review and edit notes 113

Notes and tips 4**Notes, description** 4**O****One Touch Dial** 86**Online Album** 105**P****Pause** 42

hard pause 42
two-second pause 42

Phone Info 89**Phone Safety** 127**Phone Settings** 80

Set My Shortcuts 80

Standalone Mode 80

Picture & Video 95**Picture-Video messages**

view later 63

Place a call while using Mobile Web

116

Playlist

creating a playlist 93
editing a playlist 94

R**Receive messages in call** 63**Receive text messages** 56**Receiving PICTURE Messages** 61**Receiving VIDEO Messages** 62**Record Video** 103**Reviewing sent** 66**Roaming**

definition 33
options 33

S**SAR values** 117**Security**

edit lock code 82
lock phone 83
voice privacy 87

Security settings 82**Sent, reviewing messages** 66**Set an alarm** 110**Settings** 72

backlight 78
Display settings 77
edit lock code 82
language 81
lock phone 83
security settings 82
Tools 72

Snooze 111**Sound Settings** 75**Sounds**

Alert Sounds 75
Call Sounds 75
Keypad Volume 76
Power On/Off 76
Service Alerts 76

Speed dial, assigning 47**SSL**

icon 16

Standard Limited Warranty

136

Sync Music 95

T

Text messages, receiving 56

Three-Way Calling 27

Tip, description 4

Tools 72

Alarm Clock 72, 110

Calculator 72, 107

Calendar 72, 109

converter 108

Notepad 72, 112

Stop Watch 72, 112

Tip, calculator 107

view an event 110

Voice Commands 72, 107

World Clock 72, 112

Touch Screen Navigation 21

Touch Settings 77

Auto Lock 77

Sensitivity Level 77

Vibrate Level 77

T-Ratings 129

Travel Charger 9

TTY Mode 33, 86

Turning Your Phone On and Off 9

Two-touch dialing 47

U

UL Certification 118

Understanding Your Contacts 39

Understanding Your Phone 11

features of your phone 11

Using the Battery 4

V

V CAST Video

browsing/playing clips 96

configuring alerts 97

deleting clips 97

description 95

downloading clips 96

Video clips 95

View an event, calendar 110

View Picture-Video Msg Later 63

Voice Commands

digit dial 34

name lookup 37

phone status 36

Send Text, Picture or Video 35

Voice privacy 87

Voicemail 70

listening to 10

Receive 70

setting up 10

viewing messages 70

voicemail 18

W

Wallpaper 79

Warranty Information 136